

NOTE: IF ONE EDGE OF THE TRENCH IS WITH IN 3' OF THE EDGE OF PAVEMENT, REPLACE STRUCTURAL SECTION OF PAVEMENT.

NOTES: FOR PAVED AREAS

1. PROVIDE 95% COMPACTING IN 8" LAYERS FOR THE ENTIRE DEPTH OF TRENCH.
2. POUNDING OR JETTING WILL NOT BE ALLOWED.
3. IF SOIL R-VALUE IS LESS THAN 50, USE CLASS 2 AB VERSUS NATIVE MATERIAL.
4. COMPACTION TEST SHALL BE PERFORMED BY CONTRACTOR AND BE SUBMITTED TO (AND APPROVED) BY THE COUNTY INSPECTOR PRIOR TO PAVING, USING CALTRANS TEST METHOD NO. 216 AND NO. 231.

NOTE: USE A PAVEMENT AND BASE THICKNESS OF AT LEAST 3" AND 6" RESPECTIVELY OR 1" THICKER THAN THE EXISTING A.C., WHICHEVER IS GREATER. PRIME COAT IS REQUIRED ABOVE AGGREGATE BASE.

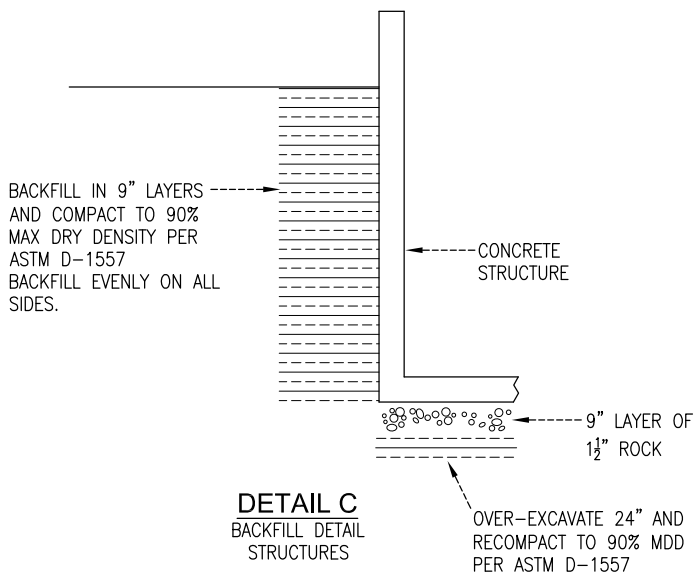

GENERAL NOTES

1. PIPE MATERIAL AND PRESSURE CLASS SHALL BE DIRECTED BY THE DISTRICT.
2. REINFORCED CONCRETE PIPELINES SHALL BE CLASS III RUBBER GASKET REINFORCED CONCRETE PIPE (RGRCP) MANUFACTURED IN ACCORDANCE WITH ASTM C-76 AND C-361.
3. PVC PIPE MAY BE MANUFACTURED IN ACCORDANCE WITH AWWA C-900, C-905 OR SHALL BE PLASTIC IRRIGATION PIPE (PIP) MANUFACTURED IN ACCORDANCE WITH ASTM D1784 AND SCS430DD. THE MINIMUM PRESSURE CLASS RATING SHALL BE 100 PSI UNLESS OTHERWISE REQUIRED BY THE DISTRICT OR BY STANISLAUS COUNTY.
4. ALL STEEL PIPE AND FITTING SHALL BE IN ACCORDANCE WITH AWWA C-200 (1/4" WALL, MINIMUM) AND SHALL BE FUSION BONDED EPOXY LINED AND COATED (12 MILS MIN.) IN ACCORDANCE WITH AWWA C-213. ALL EXPOSED PIPE SHALL BE COATED WITH 2 OR MORE COATS OF HIGH SOLIDS EPOXY IN ACCORDANCE WITH AWWA C-210. EXTERIOR TOP COAT SHALL BE A COMPATIBLE ALPHATIC POLYURETHANE.
5. CORRUGATED HIGH DENSITY POLYETHYLENE (HDPE) PIPE SHALL NOT BE ALLOWED.
6. PIPELINES WITHIN STANISLAUS COUNTY SHALL REQUIRE AN APPROVED ENCROACHMENT PERMIT FROM THE COUNTY.
7. CAST-IN-PLACE CONCRETE STRUCTURES SHALL CURE FOR A MINIMUM OF 14 DAYS PRIOR TO BACKFILL.

EXPLANATION OF SYMBOLS

- (E) EXISTING
- SDN SEE DRAWING NUMBER
- RGRCP RUBBER GASKET REINFORCED CONCRETE PIPE



PATTERSON IRRIGATION DISTRICT
PATTERSON CALIFORNIA

STANDARD DETAILS

BACKFILL REQUIREMENTS

SUMMERS ENGINEERING INC.
HANFORD Consulting Engineers CALIFORNIA

DATE: JUNE 2023	APPROVED: [Signature]
DRAWN: FJF/NV	DRAWING NO. SD-M-1
CHECKED: JCL	SHEET 1 OF 19
DRAWING NAME: PID 20011.DWG	

PATTERSON IRRIGATION DISTRICT

APPROVED _____

DATE _____

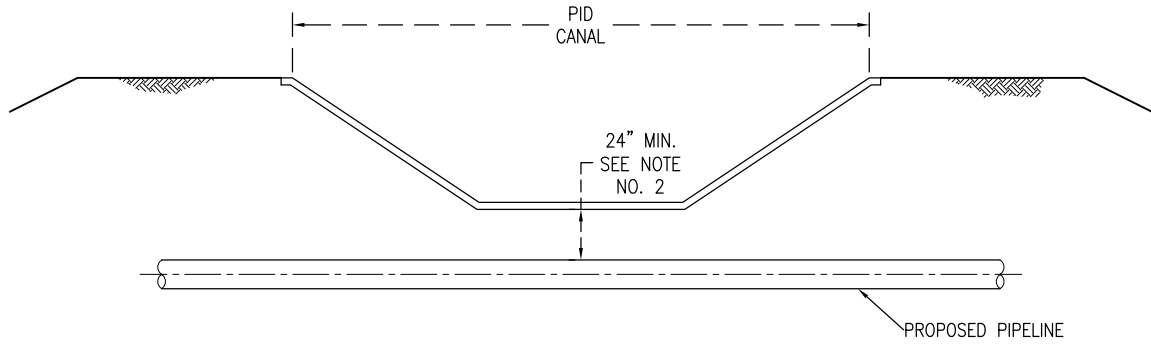

CANAL CROSSING

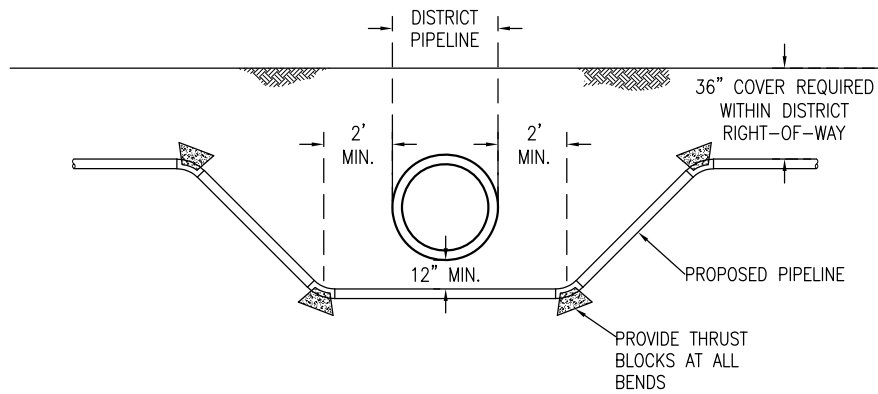

PIPELINE CROSSING

GENERAL NOTES

- █ 1. PROVIDE ALL SHEETING, SHORING, BRACING, SLOPPING, OR OTHER METHODS FOR REQUIRED WORKER SAFETY AND PROTECTION.
- █ 2. MINIMUM CLEARANCE BETWEEN TOP OF THE PROPOSED PIPE AND INVERT OF LINED CANAL SHALL BE 24" UNLESS OTHERWISE NOTED IN WRITING BY THE DISTRICT.
- █ 3. PIPELINES SHALL BE PVC, SOLID-WALL HDPE, OR REINFORCED CONCRETE.
- █ 4. PVC PIPELINES SHALL BE CLASS 100 PSI AND MEET THE STANDARDS OF AWWA C-905, AWWA C-900, OR PIP.
- █ 5. PIPELINES SHALL BE BORE/JACKETED UNDER DISTRICT CANALS UNLESS PERMISSION TO OPEN CUT IS PROVIDED IN WRITING. BORE AND RECEIVING PITS TO BE 10' FROM CANAL LINING.
- █ 6. WHEN OPEN CUT CANAL ENCROACHMENTS ARE AUTHORIZED BY THE DISTRICT, OPEN CUT AND LINING REPLACEMENT SHALL BE DONE BY THE DISTRICT AT THE OWNERS EXPENSE.
- █ 7. SEE DRAWING NUMBER SD-M-1 FOR BACKFILL REQUIREMENTS.

EXPLANATION OF SYMBOLS

- (E) EXISTING
- SDN SEE DRAWING NUMBER
- RGRCP RUBBER GASKET REINFORCED CONCRETE PIPE



PATTERSON IRRIGATION DISTRICT PATTERSON CALIFORNIA	
STANDARD DETAILS	
PIPELINE ENCROACHMENT REQUIREMENTS	
SUMMERS ENGINEERING INC. HANFORD Consulting Engineers CALIFORNIA	
DATE: ---	APPROVED:
DRAWN: NV	DRAWING NO. SD-M-2
CHECKED: JCL	SHEET 2 OF 19
DRAWING NAME: PID 20011.DWG	

PATTERSON IRRIGATION DISTRICT	
APPROVED: _____	DATE: _____

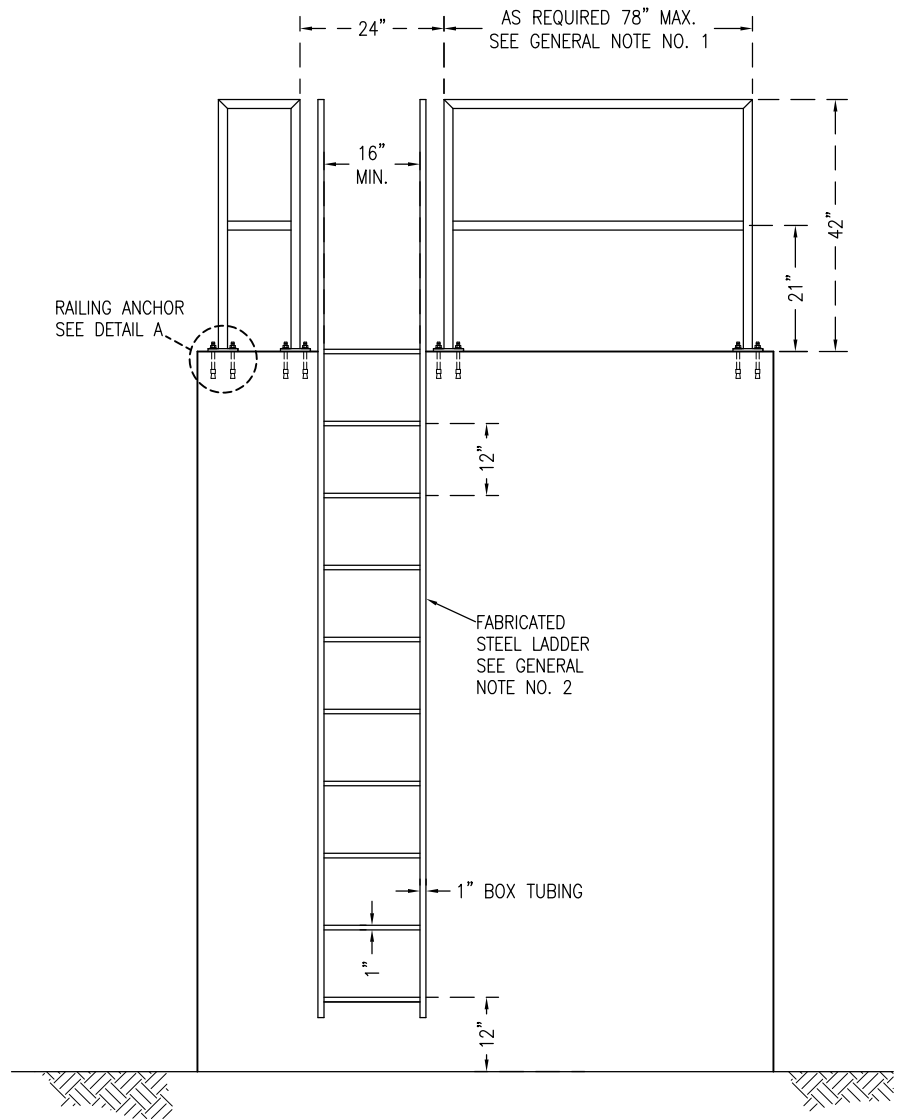
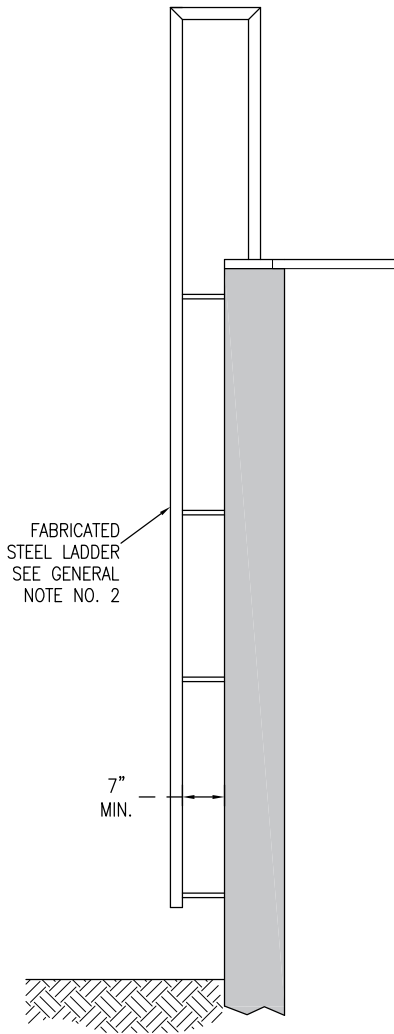

GENERAL NOTES

1. RAILING IS REQUIRED AT THE TOP OF ALL STRUCTURES 2' IN HEIGHT AND HIGHER. RAILING SHALL BE PLACED ON ALL SIDES OF THE STRUCTURE EXCEPT FOR ACCESS POINTS. RAILINGS MAY BE FABRICATED FROM 1 1/2" SCHEDULE 40 PIPE, 1 1/2"x1 1/2" BOX TUBING OR SIMILAR, WITH PANELS NO LONGER THAN 78". RAILING PANELS SHALL BE GALVANIZED AFTER FABRICATION.

2. FABRICATED ACCESS LADDERS SHALL BE GALVANIZED STEEL. ALTERNATE LADDER CONFIGURATIONS MAY BE PROPOSED PROVIDED THE LADDER MEETS APPLICATION CAL OSHA REGULATIONS. LADDERS SHALL BE GALVANIZED AFTER FABRICATION.

3. ALL NUTS, BOLTS, AND WASHER SHALL BE GALVANIZED UNLESS OTHERWISE NOTED.

EXPLANATION OF SYMBOLS

- (E) EXISTING
- SDN SEE DRAWING NUMBER
- RGRCP RUBBER GASKET REINFORCED CONCRETE PIPE

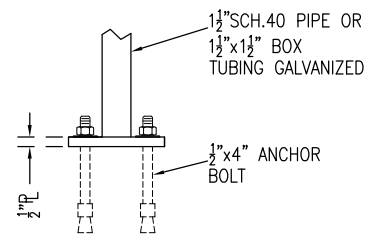
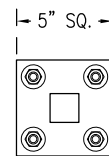

DETAIL A



PATTERSON IRRIGATION DISTRICT PATTERSON CALIFORNIA	
STANDARD DETAILS	
RAILING AND ACCESS LADDERS	
SUMMERS ENGINEERING INC. HANFORD Consulting Engineers CALIFORNIA	
DATE: ---	APPROVED:
DRAWN: FJF	DRAWING NO. SD-M-3
CHECKED: JCL	SHEET 3 OF 19
DRAWING NAME: PID 20011.DWG	

PATTERSON IRRIGATION DISTRICT	
APPROVED: _____	DATE: _____

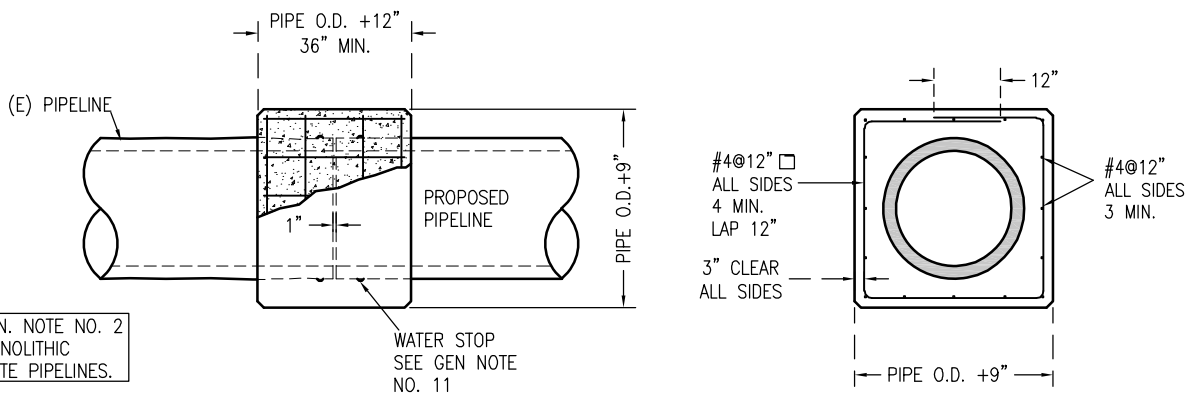

SEE GEN. NOTE NO. 2 FOR MONOLITHIC CONCRETE PIPELINES.

PIPELINE CONNECTION BLOCK DETAIL

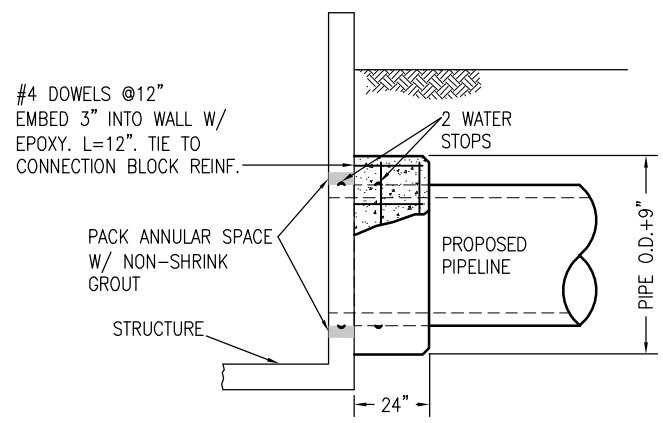

HEADWALL CONNECTION BLOCK DETAIL

GENERAL NOTES

- 1. PROVIDE ALL SHEETING, SHORING, BRACING, SLOPPING, OR OTHER METHODS FOR REQUIRED WORKER SAFETY AND PROTECTION.
- 2. EXISTING PIPELINE TO BE SAW-CUT TO A CLEAN EDGE. EXISTING MONOLITHIC CONCRETE PIPELINES SHALL BE INSPECTED FOR LONGITUDINAL CRACKING PRIOR TO THE CONNECTION BLOCK CONSTRUCTION. IF LONGITUDINAL CRACKS ARE DISCOVERED, CONSTRUCTION SHALL STOP AND DISTRICT STAFF SHALL BE NOTIFIED IMMEDIATELY.
- 3. NEW PIPELINES SHALL BE RUBBER GASKET REINFORCED CONCRETE (RGRCP) OR STEEL.
- 4. THIS STANDARD DOES NOT APPLY TO PVC PIPE CONNECTIONS, SEE DWG. NO. SD-P-2 FOR PVC PIPE CONNECTIONS.
- 5. STEEL PIPE AND FITTINGS SHALL BE IN ACCORDANCE WITH AWWA C-200 (1/4" WALL MINIMUM). ALL STEEL FLANGES SHALL IN ACCORDANCE WITH AWWA C-207, CLASS D. ALL PIPE, FLANGES, AND MECHANICAL COUPLINGS SHALL BE FUSION BONDED EPOXY LINED AND COATED (12 MILS MIN.) IN ACCORDANCE WITH AWWA C-213. ALL EXPOSED PIPE SHALL BE COATED WITH 2 OR MORE COATS OF HIGH SOLIDS EPOXY IN ACCORDANCE WITH AWWA C-210. EXTERIOR TOP COAT SHALL BE A COMPATIBLE ALPHATIC POLYURETHANE.
- 6. CONCRETE PIPELINES SHALL BE CLASS III RUBBER GASKET REINFORCED CONCRETE PIPE (RGRCP) MANUFACTURED IN ACCORDANCE WITH ASTM C-76 AND 361.
- 7. REINFORCED CONCRETE SHALL DEVELOPED A MINIMUM COMPRESSIVE STRENGTH OF 3000 PSI. CEMENT SHALL BE TYPE II IN ACCORDANCE WITH ASTM C-150. A MINIMUM OF 5 1/2 SACKS OF CEMENT TO EACH CUBIC YARDS TO EACH CUBIC YARD OF CONCRETE SHALL BE USED.
- 8. ALL REINFORCING BARS SHALL BE GRADE 60. CONFORMING TO ASTM A-615 OR A-706. ALL REINFORCING BARS BENDS SHALL HAVE A MINIMUM RADIUS OF FOUR BAR DIAMETERS AND SPLICES SHALL BE LAPPED FORTY BAR DIAMETERS.
- 9. CHAMFER ALL EXPOSED CORNERS OF CONCRETE 1"±. HAUNCH ALL INTERIOR CORNERS OF CONCRETE 1"± EXCEPT WHERE NOTED OTHERWISE.
- 10. SEE STANDARD DETAIL NO. SD-M-1 FOR BACKFILL REQUIREMENTS.
- 11. WATER STOP SHALL BE SIKA HYDROTITE HYDROLIC PLACED AROUND OUTSIDE OF ALL PENETRATING PIPES. WITH PRIMER. WATER STOPS SHALL BE PLACED BOTH WITHIN THE STRUCTURE WALL AND CONNECTION BLOCK.

EXPLANATION OF SYMBOLS

- (E) EXISTING
- SDN SEE DRAWING NUMBER
- RGRCP RUBBER GASKET REINFORCED CONCRETE PIPE



PATTERSON IRRIGATION DISTRICT PATTERSON CALIFORNIA	
STANDARD DETAILS	
PIPELINE CONNECTION BLOCK DETAILS	
SUMMERS ENGINEERING INC. HANFORD CONSULTING ENGINEERS CALIFORNIA	
DATE: ---	APPROVED:
DRAWN: NV	DRAWING NO. SD-P-1
CHECKED: JCL	SHEET: 4 OF 19
DRAWING NAME: PID 20011.DWG	

PATTERSON IRRIGATION DISTRICT	
APPROVED: _____	DATE: _____

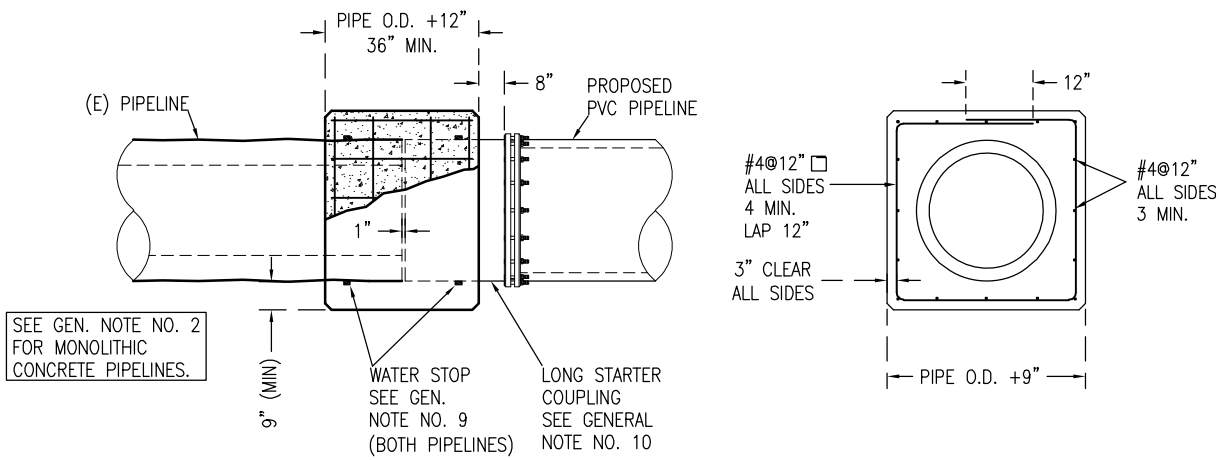

PVC PIPELINE CONNECTION BLOCK DETAIL

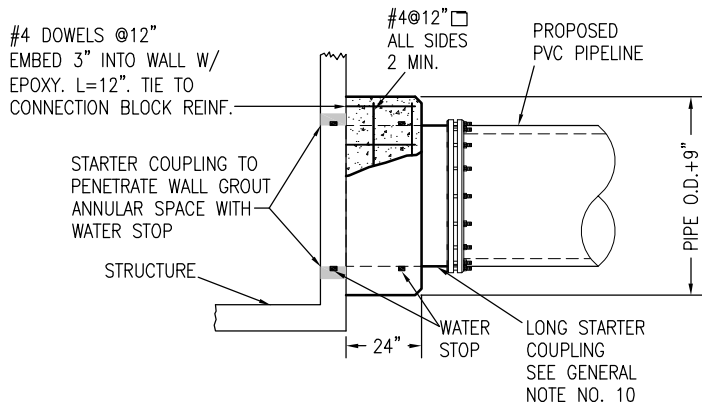

PVC PIPE HEADWALL CONNECTION BLOCK DETAIL

GENERAL NOTES

- 1. PROVIDE ALL SHEETING, SHORING, BRACING, SLOPPING, OR OTHER METHODS FOR REQUIRED WORKER SAFETY AND PROTECTION.
- 2. EXISTING PIPELINE TO BE SAW-CUT TO A CLEAN EDGE. EXISTING MONOLITHIC PIPELINES SHALL BE INSPECTED FOR LONGITUDINAL CRACKING PRIOR TO THE CONNECTION BLOCK CONSTRUCTION. IF LONGITUDINAL CRACKS ARE DISCOVERED, CONSTRUCTION SHALL STOP AND DISTRICT STAFF SHALL BE NOTIFIED IMMEDIATELY.
- 3. NEW PIPELINES INSTALLED UNDER THIS STANDARD SHALL BE PVC.
- 4. PVC PIPE MAY BE MANUFACTURED IN ACCORDANCE WITH AWWA C-900, C-905 OR SHALL BE PLASTIC IRRIGATION PIPE (PIP) MANUFACTURED IN ACCORDANCE WITH ASTM D1784 AND SCS430DD. THE MINIMUM PRESSURE CLASS RATING SHALL BE 100 PSI UNLESS OTHERWISE REQUIRED BY THE DISTRICT.
- 5. REINFORCED CONCRETE SHALL DEVELOPED A MINIMUM COMPRESSIVE STRENGTH OF 3000PSI. CEMENT SHALL BE TYPE II IN ACCORDANCE WITH ASTM C-150. A MINIMUM OF 5½ SACKS OF CEMENT TO EACH CUBIC YARD OF CONCRETE SHALL BE USED.
- 6. ALL REINFORCING BARS SHALL BE GRADE 60, CONFORMING TO ASTM A-615 OR A-706. ALL REINFORCING BARS BENDS SHALL HAVE A MINIMUM RADIUS OF FOUR BAR DIAMETERS AND SPLICES SHALL BE LAPPED FORTY BAR DIAMETERS.
- 7. CHAMFER ALL EXPOSED CORNERS OF CONCRETE 1"±. HAUNCH ALL INTERIOR CORNERS OF CONCRETE 1"± EXCEPT WHERE NOTED OTHERWISE.
- 8. SEE STANDARD DETAIL NO. SD-M-1 FOR BACKFILL REQUIREMENTS.
- 9. WATER STOP SHALL BE SIKA HYDROTITE HYDROLIC PLACED AROUND OUTSIDE OF ALL PENETRATING PIPES. WITH PRIMER. WATER STOPS SHALL BE PLACED BOTH WITHIN THE STRUCTURE WALL AND CONNECTION BLOCK.
- 10. PVC PIPELINES SHALL BE CONNECTED TO THE CONNECTION BLOCK OR STRUCTURE WITH A MORRIL INDUSTRIES GALVANIZED STEEL LONG STARTER COUPLING.

EXPLANATION OF SYMBOLS

- (E) EXISTING
- SDN SEE DRAWING NUMBER
- RGRC RUBBER GASKET REINFORCED CONCRETE PIPE



PATTERSON IRRIGATION DISTRICT PATTERSON CALIFORNIA	
STANDARD DETAILS	
PVC PIPE CONNECTION BLOCK DETAILS	
SUMMERS ENGINEERING INC. HANFORD CONSULTING ENGINEERS CALIFORNIA	
DATE: ---	APPROVED:
DRAWN: NV	DRAWING NO. SD-P-2
CHECKED: JCL	SHEET: 5 OF 19
DRAWING NAME: PID 20011.DWG	

PATTERSON IRRIGATION DISTRICT	
APPROVED: _____	DATE: _____

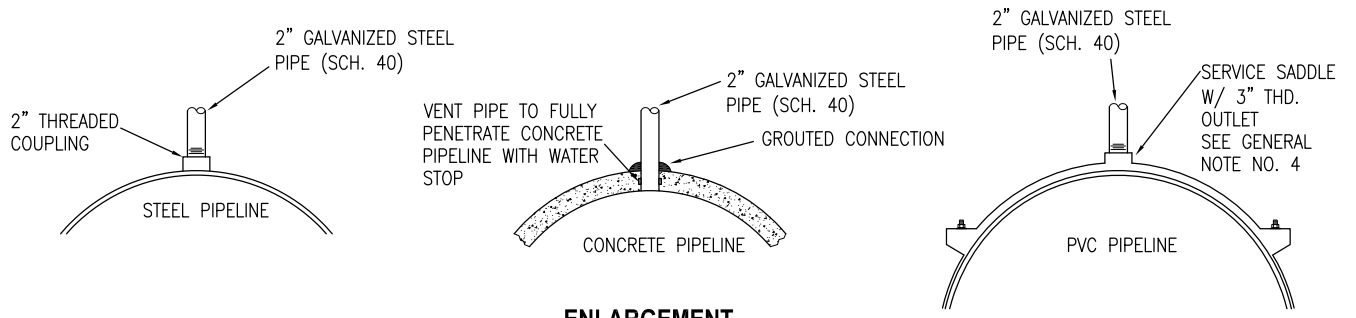

ENLARGEMENT

* UNLESS OTHERWISE REQUIRED BY THE DISTRICT

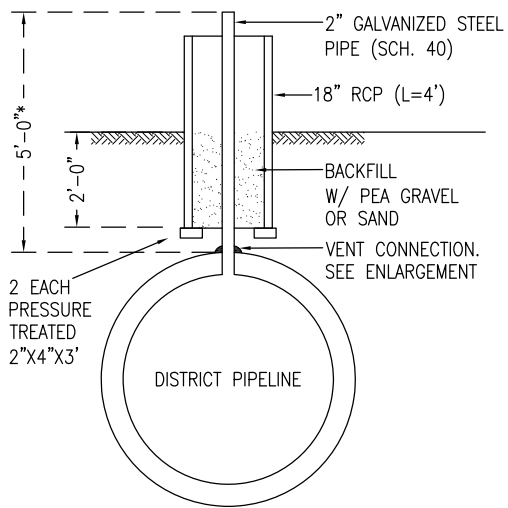

AIR VENT DETAIL

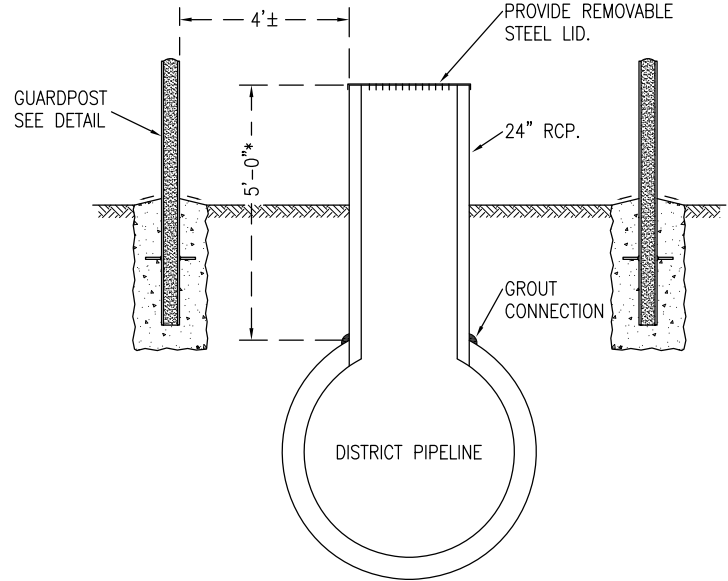

MANHOLE DETAIL

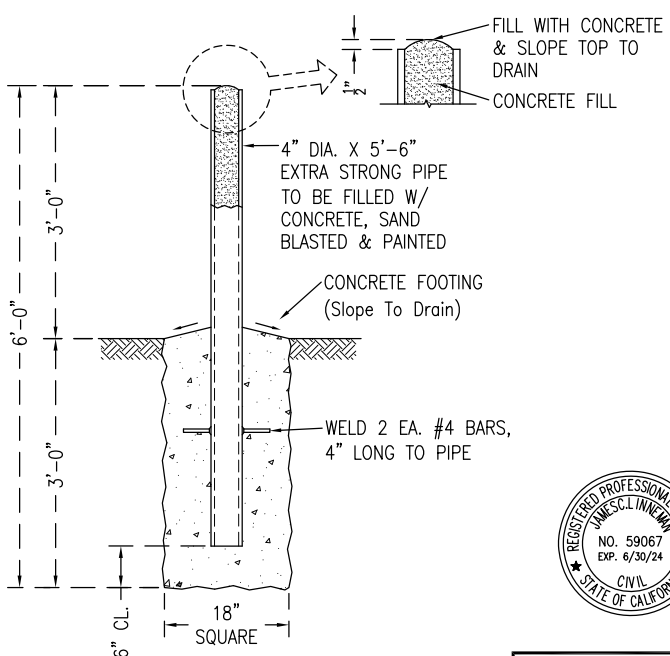

GUARD POST DETAIL

GENERAL NOTES

- 1. AIR VENT AND MANHOLES SHALL BE INSTALLED WHERE REQUIRED BY THE DISTRICT.
- 2. ALL VENT PIPE AND MANHOLE CONNECTIONS SHALL BE WATER TIGHT.
- 3. WATERSTOP SHALL BE SIKA HYDROTITE HYDROPHALIC PLACED AROUND OUTSIDE OF ALL PENETRATING PIPES.
- 4. SERVICE SADDLE SHALL BE MODEL 101NS, 202NS, OR FTS20T BY ROMAC OR APPROVED EQUAL.

EXPLANATION OF SYMBOLS

- (E) EXISTING
- SDN SEE DRAWING NUMBER
- RGRCP RUBBER GASKET REINFORCED CONCRETE PIPE



PATTERSON IRRIGATION DISTRICT PATTERSON CALIFORNIA	
STANDARD DETAILS	
PIPELINE VENT & MANHOLE DETAIL	
SUMMERS ENGINEERING INC. Consulting Engineers CALIFORNIA	
HANFORD	
DATE: JUNE 2023	APPROVED:
DRAWN: NV	DRAWING NO.: SD-P-3
CHECKED: JCL	SHEET: 6 of 19
DRAWING NAME: PID 20011.DWG	

PATTERSON IRRIGATION DISTRICT

APPROVED: _____

DATE: _____

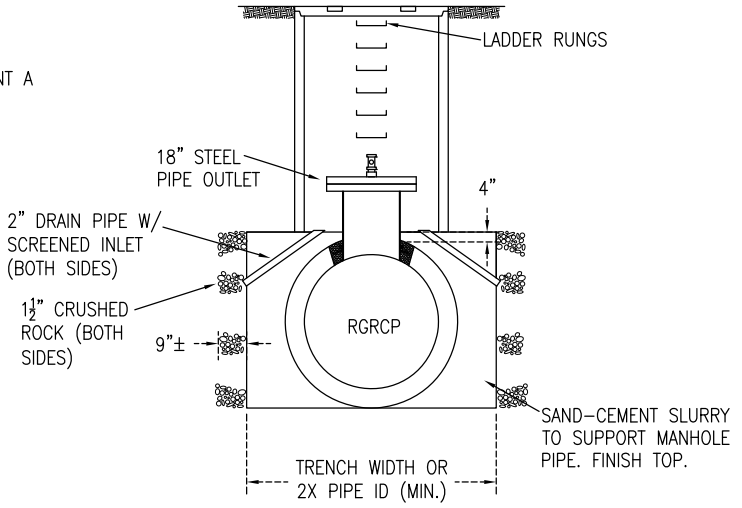
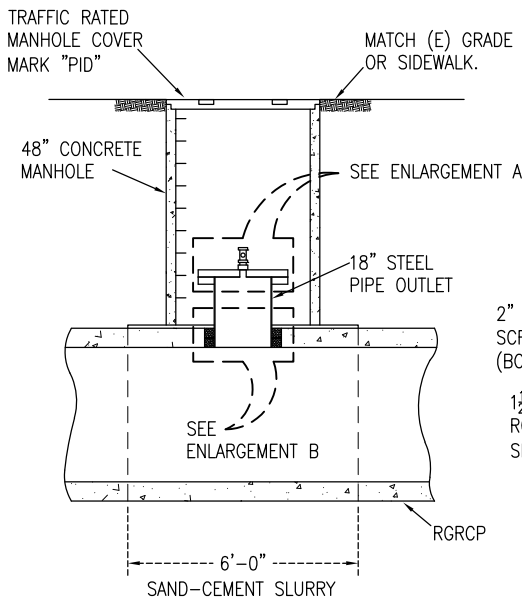

PRESSURE MANHOLE DETAIL

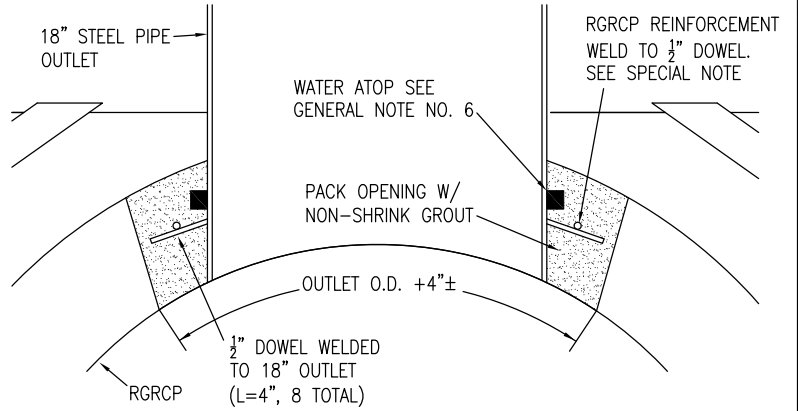
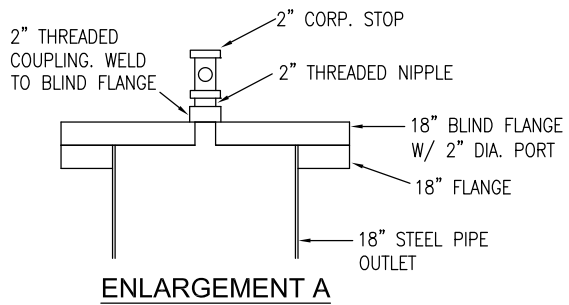

ENLARGEMENT B

SPECIAL NOTE: INSTALLATION OF A PRESSURE MANHOLE ON AN EXISTING RGRCP SHALL BE AS FOLLOWS:

1. CUT OPENING IN (E) RGRCP AT OUTLET OD+4". RETAIN RGRCP REINFORCEMENT.
2. CUT AND PULL BACK RGRCP REINFORCEMENT.
3. PLACE STEEL OUTLET IN OPENING & WELD RGRCP REINFORCEMENT TO OUTLET DOWELS.
4. PACK OPENING W/ NON-SHRINK GROUT. MANHOLE CONNECT SHALL BE WATER-TIGHT.

GENERAL NOTES

1. ALL CONNECTIONS SHALL BE WATER TIGHT.
2. THIS STANDARD DOES NOT APPLY TO MONOLITHIC CONCRETE PIPE.
3. ALL STEEL PIPE AND FITTINGS SHALL BE IN ACCORDANCE WITH AWWA C-200 (1/4" WALL, MINIMUM). ALL STEEL FLANGES SHALL BE IN ACCORDANCE WITH AWWA C-207, CLASS D. ALL PIPES & FLANGES SHALL BE FUSION BONDED EPOXY LINED AND COATED (12 MILS MIN.) IN ACCORDANCE WITH AWWA C-213 AND INCLUDE NUT/BOLT & GASKET KITS. 1/2" DOWELS SHALL BE BARE STEEL.
4. DRAIN PIPE INLET SHALL BE FLUSH W/ FINISHED SLURRY SURFACE. PLACE DRAIN ROCK FROM TOP OF SLURRY TO BOTTOM FOR FULL WIDTH OF SLURRY BLOCK.
5. SEE STANDARD DETAIL NO. SD-M-1 FOR BACKFILL REQUIREMENTS.
6. WATERSTOP SHALL BE SIKA HYDROTITE HYDROPHALIC PLACED AROUND OUTSIDE OF ALL PENETRATING PIPES.

EXPLANATION OF SYMBOLS

- (E) EXISTING
- SDN SEE DRAWING NUMBER
- RGRCP RUBBER GASKET REINFORCED CONCRETE PIPE



PATTERSON IRRIGATION DISTRICT PATTERSON CALIFORNIA	
STANDARD DETAILS	
CONCRETE PIPE PRESSURE MANHOLE DETAIL	
SUMMERS ENGINEERING INC. HANFORD Consulting Engineers CALIFORNIA	
DATE: ---	APPROVED:
DRAWN: NV	DRAWING NO. SD-P-4
CHECKED: JCL	SHEET: 7 OF 19
DRAWING NAME: PID 20011.DWG	

PATTERSON IRRIGATION DISTRICT	
APPROVED: _____	DATE: _____

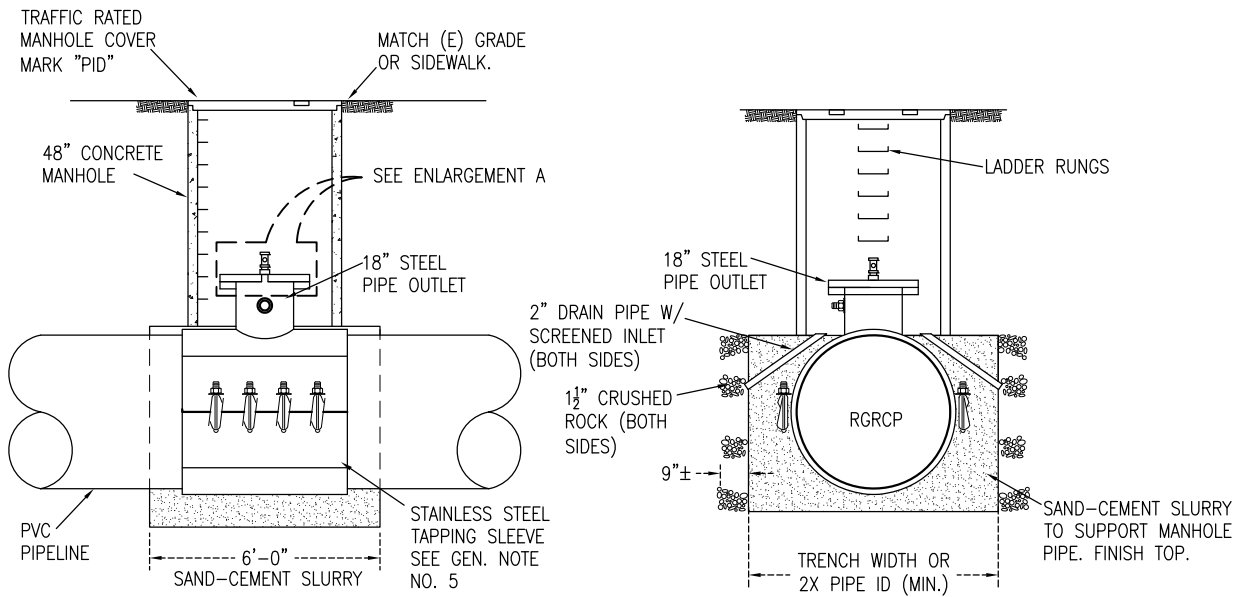

PRESSURE MANHOLE DETAIL

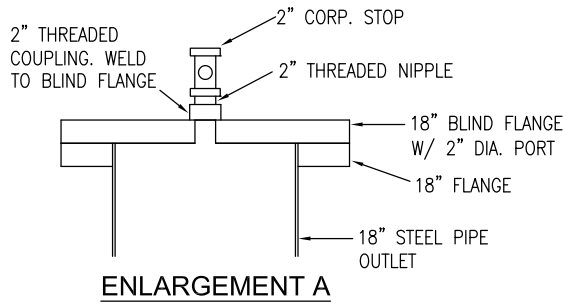

GENERAL NOTES

- 1. ALL CONNECTIONS SHALL BE WATER TIGHT.
- 2. THIS STANDARD DOES NOT APPLY TO MONOLITHIC CONCRETE PIPE.
- 3. ALL STEEL PIPE AND FITTINGS SHALL BE IN ACCORDANCE WITH AWWA C-200 (1/4" WALL, MINIMUM). ALL STEEL FLANGES SHALL BE IN ACCORDANCE WITH AWWA C-207, CLASS D. ALL PIPES & FLANGES SHALL BE FUSION BONDED EPOXY LINED AND COATED (12 MILS MIN.) IN ACCORDANCE WITH AWWA C-213 AND SHALL INCLUDE NUT/BOLT & GASKET KITS. 1/2" DOWELS SHALL BE BARE STEEL.
- 4. DRAIN PIPE INLET SHALL BE FLUSH W/ FINISHED SLURRY SURFACE. PLACE DRAIN ROCK FROM TOP OF SLURRY TO BOTTOM FOR FULL WIDTH OF SLURRY BLOCK.
- 5. THE STAINLESS STEEL TAPPING SLEEVE SHALL BE MODEL SST III OR STS420 BY ROMAC OR APPROVED EQUAL. ALL NUTS BOLTS AND WASHERS SHALL BE STAINLESS.
- 6. SEE STANDARD DETAIL NO. SD-M-1 FOR BACKFILL REQUIREMENTS.

EXPLANATION OF SYMBOLS

- (E) EXISTING
- SDN SEE DRAWING NUMBER
- RGRCP RUBBER GASKET REINFORCED CONCRETE PIPE



PATTERSON IRRIGATION DISTRICT PATTERSON CALIFORNIA	
STANDARD DETAILS	
PVC PIPE PRESSURE MANHOLE DETAIL	
SUMMERS ENGINEERING INC. HANFORD Consulting Engineers CALIFORNIA	
DATE ---	APPROVED
DRAWN NV	DRAWING NO. SD-P-5
CHECKED JCL	SHEET 8 OF 19
DRAWING NAME : PID 20011.DWG	

PATTERSON IRRIGATION DISTRICT	
APPROVED _____	DATE _____

GENERAL NOTES

- 1. REINFORCED CONCRETE SHALL DEVELOP A MINIMUM COMPRESSIVE STRENGTH OF 3000 PSI. CEMENT SHALL BE TYPE II IN ACCORDANCE WITH ASTM C-150. A MINIMUM OF 5 1/2 SACKS OF CEMENT TO EACH CUBIC YARD OF CONCRETE SHALL BE USED.
- 2. ALL REINFORCING BARS SHALL BE GRADE 60, CONFORMING TO ASTM A-615 OR A-706. ALL REINFORCING BAR BENDS SHALL HAVE A MINIMUM RADIUS OF FOUR BAR DIAMETERS AND SPLICES SHALL BE LAPPED FORTY BAR DIAMETERS.
- 3. TYPE I TURNOUT BOX MAY BE STACKED NO HIGHER THAN 6 FEET ABOVE GROUND LEVEL. SEE DWG. NO. SD-12 FOR BOXES TALLER THEN 6 FEET ABOVE GROUND LEVEL.
- 4. ALTERNATE END JOINT DETAILS MAY BE PROPOSED FOR REVIEW.
- 5. WATERSTOP SHALL BE SIKA HYDROTITE HYDROPHALIC PLACED AROUND OUTSIDE OF ALL PENETRATING PIPES.
- 6. SEE DWG. NO. SD-P-1 AND SD-P-2 FOR CONNECTION BLOCK REQUIREMENTS.
- 7. PRE-CAST CONCRETE TURNOUT BOXES BY MACHADO BACKHOE, INC. ARE ACCEPTABLE FOR THE TYPE I TURNOUT BOX.
- 8. SEE DRAWING NUMBER SD-M-1 FOR BACKFILL REQUIREMENTS.

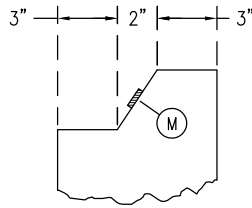

END JOINT DETAIL
MIRROR FOR OPPOSITE END.

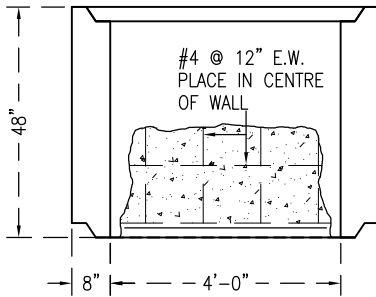

SECTION A-A: NO OPENING

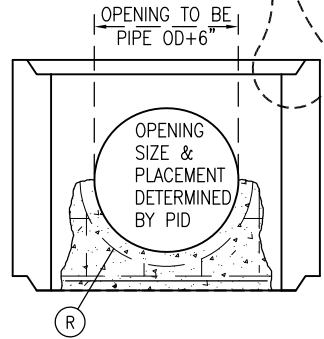

SECTION A-A: WITH OPENING

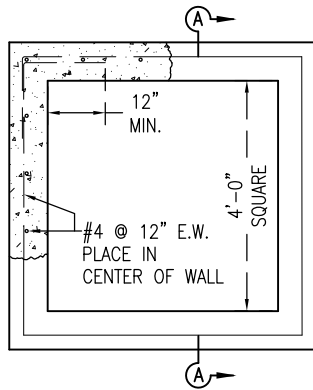

STANDARD BOX SECTION

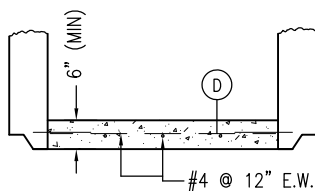

FLOOR DETAIL

EXPLANATION OF SYMBOLS

- (E) EXISTING
- (M) 1 1/2" WIDE MASTIC GASKET STRIP BY RAM-NEK OR APPROVED EQUAL
- (R) #5 BAR RING. WELD TO INTERSECTING REINF.
- RGRCP RUBBER GASKET REINFORCED CONCRETE PIPE
- SDN SEE DRAWING NUMBER



PATTERSON IRRIGATION DISTRICT PATTERSON CALIFORNIA	
STANDARD DETAILS	
TURNOUT BOX TYPE I	
SUMMERS ENGINEERING INC. HANFORD Consulting Engineers CALIFORNIA	
DATE: ---	APPROVED:
DRAWN: FJF	DRAWING NO. SD-T-1
CHECKED: JCL	SHEET 9 OF 19
DRAWING NAME: PID 20011.DWG	

PATTERSON IRRIGATION DISTRICT	
APPROVED: _____	DATE: _____

GENERAL NOTES

- 1. REINFORCED CONCRETE SHALL DEVELOP A MINIMUM COMPRESSIVE STRENGTH OF 3000 PSI. CEMENT SHALL BE TYPE II IN ACCORDANCE WITH ASTM C-150. A MINIMUM OF 5 1/2 SACKS OF CEMENT TO EACH CUBIC YARD OF CONCRETE SHALL BE USED.
- 2. ALL REINFORCING BARS SHALL BE GRADE 60, CONFORMING TO ASTM A-615 OR A-706. ALL REINFORCING BAR BENDS SHALL HAVE A MINIMUM RADIUS OF FOUR BAR DIAMETERS AND SPLICES SHALL BE LAPPED FORTY BAR DIAMETERS.
- 3. TYPE II TURNOUT BOX MAY BE STACKED NO HIGHER THAN 20 FEET ABOVE GROUND LEVEL.
- 4. ALTERNATE END JOINT DETAILS MAY BE PROPOSED FOR REVIEW.
- 5. WATERSTOP SHALL BE SIKA HYDROTITE HYDROPHALIC PLACED AROUND OUTSIDE OF ALL PENETRATING PIPES.
- 6. SEE DWG. NO. SD-P-1 AND SD-P-2 FOR CONNECTION BLOCK REQUIREMENTS.
- 7. SEE DRAWING NUMBER SD-M-1 FOR BACKFILL REQUIREMENTS.

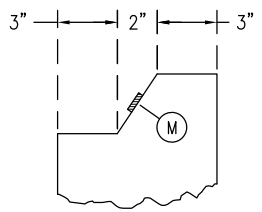

END JOINT DETAIL
MIRROR FOR OPPOSITE END.

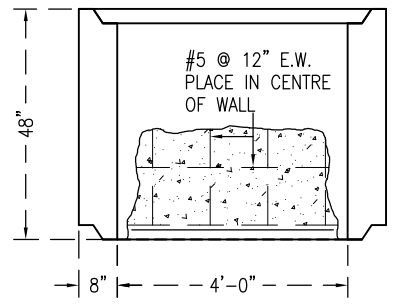

SECTION A-A: NO OPENING

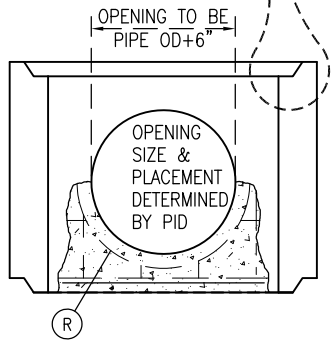

SECTION A-A: WITH OPENING

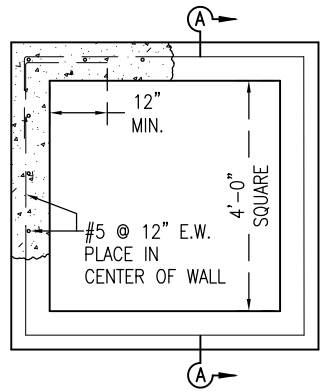

STANDARD BOX SECTION

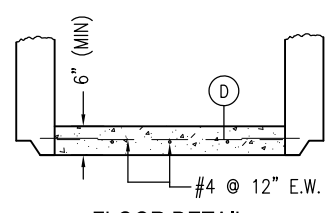

FLOOR DETAIL

EXPLANATION OF SYMBOLS

- (E) EXISTING
- (M) 1 1/2" WIDE MASTIC GASKET STRIP BY RAM-NEK OR APPROVED EQUAL
- (R) #5 BAR RING, WELD TO INTERSECTING REINF.
- RGRCP RUBBER GASKET REINFORCED CONCRETE PIPE
- SDN SEE DRAWING NUMBER



PATTERSON IRRIGATION DISTRICT PATTERSON CALIFORNIA	
STANDARD DETAILS	
TURNOUT BOX TYPE II	
SUMMERS ENGINEERING INC. HANFORD Consulting Engineers CALIFORNIA	
DATE: ---	APPROVED:
DRAWN: FJF	DRAWING NO. SD-T-2
CHECKED: JCL	SHEET 10 of 19
DRAWING NAME: PID 20011.DWG	

PATTERSON IRRIGATION DISTRICT	
APPROVED: _____	DATE: _____

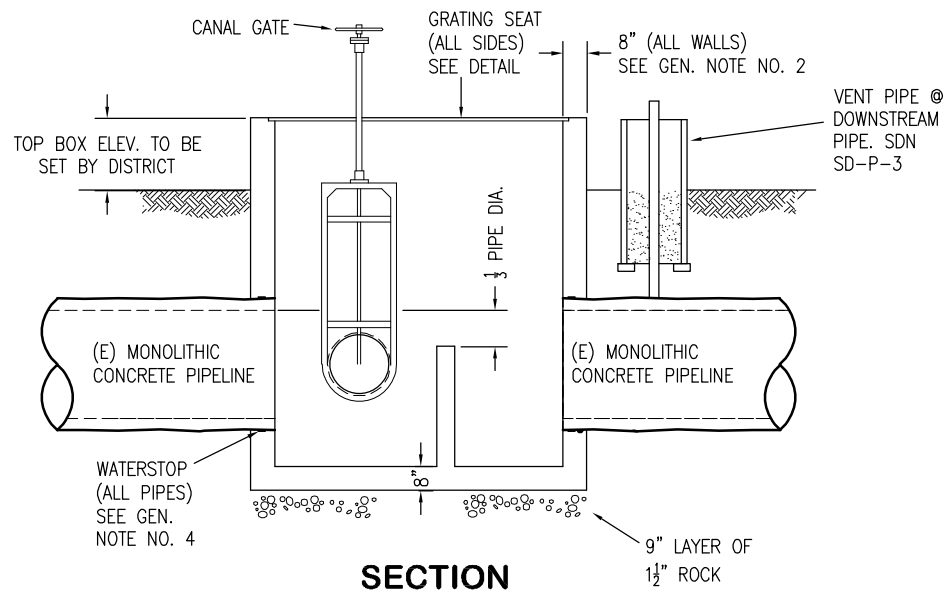

SECTION

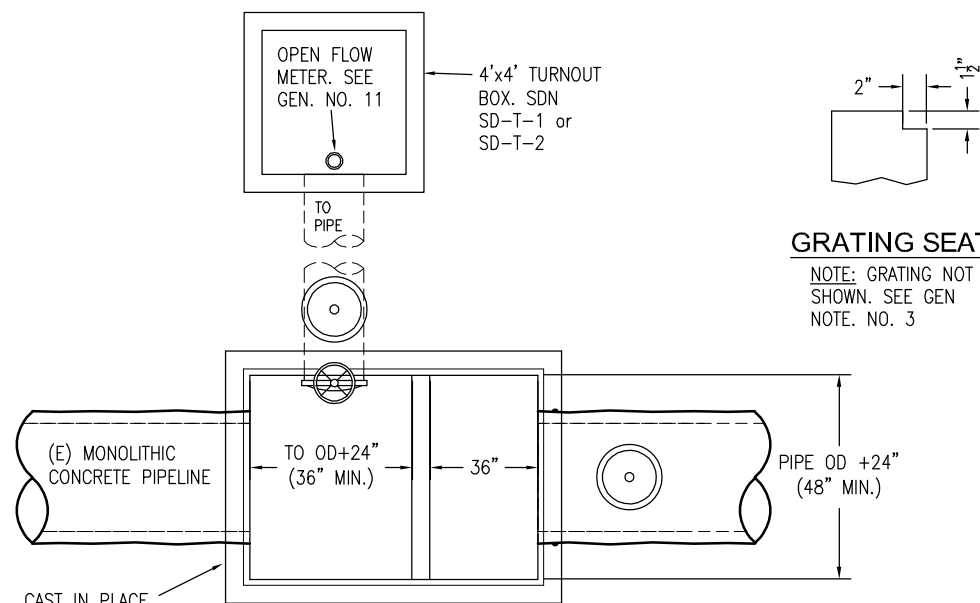

PLAN

GRATING SEAT

NOTE: GRATING NOT SHOWN. SEE GEN NOTE. NO. 3

GENERAL NOTES

- 1. REINFORCED CONCRETE SHALL DEVELOP A MINIMUM COMPRESSIVE STRENGTH OF 4000 PSI. CEMENT SHALL BE TYPE II IN ACCORDANCE WITH ASTM C-150. A MINIMUM OF 6 SACKS OF CEMENT TO EACH CUBIC YARD OF CONCRETE SHALL BE USED.
- 2. REINF. SHALL BE #5@12" E.W. PLACED IN CTR OF WALLS. ALL REINFORCING BARS SHALL BE GRADE 60, CONFORMING TO ASTM A-615 OR A-706. ALL REINFORCING BAR BENDS SHALL HAVE A MINIMUM RADIUS OF FOUR BAR DIAMETERS AND SPLICES SHALL BE LAPPED FORTY BAR DIAMETERS.
- 3. GRATING (NOT SHOWN) SHALL BE 19-W-4 W/ 1 1/2" BEARING BARS BY GRATING PACIFIC OR APPROVED EQUAL. GRATING SHALL BE GALVANIZED W/ BANDED ENDS. SLOTS FOR GATE FRAMES SHALL BE PRECUT W/ 1" CLEARANCE ON ALL SIDES.
- 4. WATERSTOP SHALL BE SIKA HYDROTITE HYDROPHALIC PLACED AROUND OUTSIDE OF ALL PENETRATING PIPES.
- 5. SUBGRADE TO BE COMPACTED TO 90% MAX DRY DENSITY PER ASTM D-1557 PRIOR TO PLACEMENT OF ROCK.
- 6. CANAL GATES SHALL BE SUPPLIED BY THE DISTRICT AT THE OWNER'S EXPENSE AND INSTALLED BY THE OWNER.
- 7. PVC PIPE LATERALS SHALL BE CONNECTED TO CONTROL STRUCTURES WITH A MORRIL INDUSTRIES GALV. STEEL STARTER COUPLING. STARTER COUPLING SHALL BE CAST INTO THE CONTROL BOX.

- 8. WALL OPENINGS SHALL BE REINFORCED WITH #6 BAR CIRCULAR RING AT OPENING DIA. +6" AND TIED TO WALL REINF.
- 9. (E) MONOLITHIC PIPE SHALL BE SAW-CUT AND INSPECTED FOR LONGITUDINAL CRACKING PRIOR TO CONSTRUCTION OF THE TURNOUT BOX. IF LONGITUDINAL CRACKS ARE DISCOVERED, CONSTRUCTION SHALL STOP AND THE DISTRICT SHALL BE NOTIFIED.
- 10. TURNOUT BOX SHALL BE POURED IN PLACE AROUND THE (E) MONOLITHIC PIPE. PRE-CAST BOXES SHALL NOT BE ALLOWED W/O WRITTEN PERMISSION FROM THE DISTRICT.
- 11. THE OPEN FLOW METER SHALL BE OF-12D BY WATER SPECIALTIES. THE METER SHALL INDICATE IN CUBIC FEET PER SECOND AND TOTALIZE IN ACRE FEET. METER LENGTH SHALL BE SET SO THAT PROPELLER IS CENTERED IN THE PIPE AND THE METER HEAD IS READABLE FROM THE TOP OF THE BOX.
- 12. SEE DRAWING NO. SD-M-1 FOR BACKFILL REQUIREMENTS.
- 13. SEE DRAWING NO. SD-M-3 FOR RAILING AND LADDER REQUIREMENTS.



EXPLANATION OF SYMBOLS

- (E) EXISTING
- SDN SEE DRAWING NUMBER
- RGRCP RUBBER GASKET REINFORCED CONCRETE PIPE

PATTERSON IRRIGATION DISTRICT PATTERSON CALIFORNIA	
STANDARD DETAILS	
MONOLITHIC CONCRETE PIPE TURNOUT INSTALLATION	
SUMMERS ENGINEERING INC. Consulting Engineers CALIFORNIA	
DATE: --- DRAWN: FJF CHECKED: JCL DATE: _____	APPROVED: _____ DRAWING NO. SD-T-3 SHEET 11 OF 19 DRAWING NAME: PID 20011.DWG

PATTERSON IRRIGATION DISTRICT	
APPROVED: _____ DATE: _____	DATE: --- DRAWN: FJF CHECKED: JCL DATE: _____

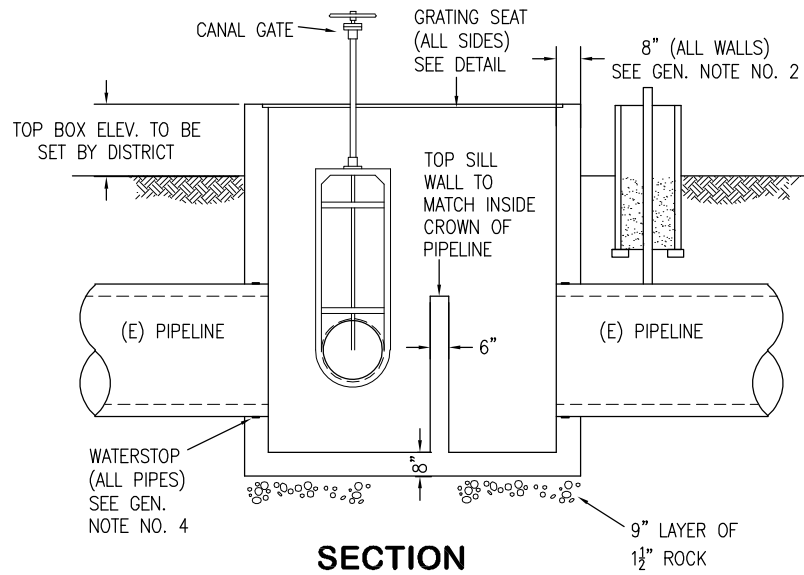

SECTION

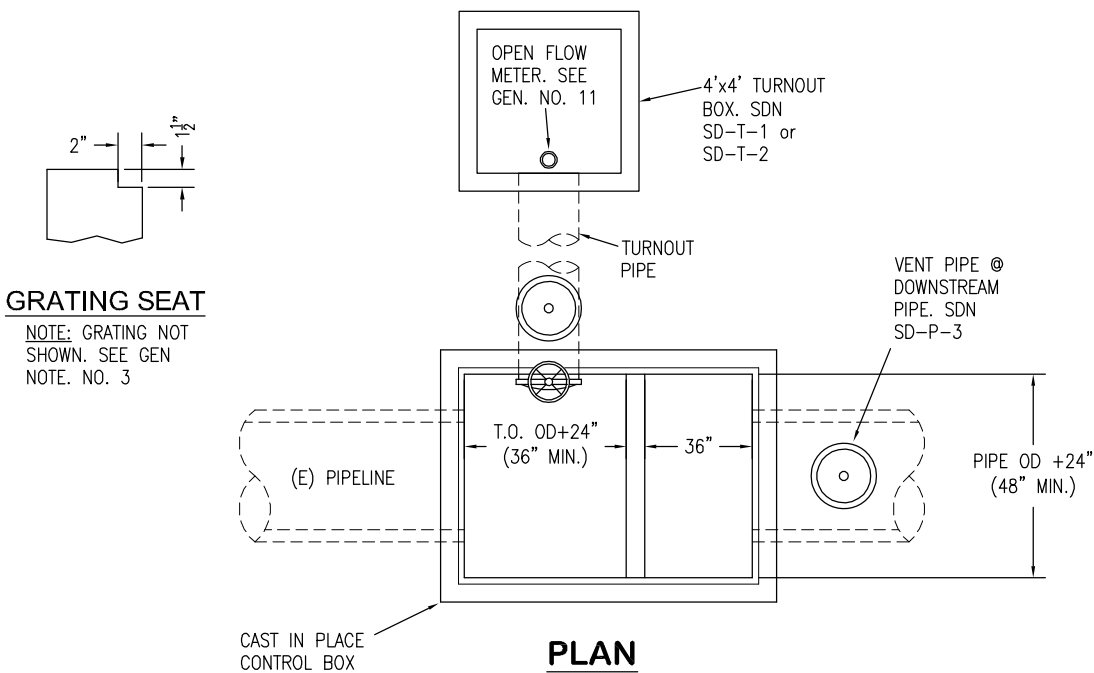

GRATING SEAT

NOTE: GRATING NOT SHOWN. SEE GEN. NOTE. NO. 3

GENERAL NOTES

- 1. REINFORCED CONCRETE SHALL DEVELOP A MINIMUM COMPRESSIVE STRENGTH OF 4000 PSI. CEMENT SHALL BE TYPE II IN ACCORDANCE WITH ASTM C-150. A MINIMUM OF 6 SACKS OF CEMENT TO EACH CUBIC YARD OF CONCRETE SHALL BE USED.
- 2. REINF. SHALL BE #5@12" E.W. PLACED IN CTR OF WALLS. ALL REINFORCING BARS SHALL BE GRADE 60, CONFORMING TO ASTM A-615 OR A-706. ALL REINFORCING BAR BENDS SHALL HAVE A MINIMUM RADIUS OF FOUR BAR DIAMETERS AND SPLICES SHALL BE LAPPED FORTY BAR DIAMETERS.
- 3. GRATING (NOT SHOWN) SHALL BE 19-W-4 W/ 1 1/2" BEARING BARS BY GRATING PACIFIC OR APPROVED EQUAL. GRATING SHALL BE GALVANIZED W/ BANDED ENDS. SLOTS FOR GATE FRAMES SHALL BE PRECUT W/ 1" CLEARANCE ON ALL SIDES.
- 4. WATERSTOP SHALL BE SIKA HYDROTITE HYDROPHALIC PLACED AROUND OUTSIDE OF ALL PENETRATING PIPES.
- 5. SUBGRADE TO BE COMPACTED TO 90% MAX DRY DENSITY PER ASTM D-1557 PRIOR TO PLACEMENT OF ROCK.
- 6. CANAL GATES SHALL BE SUPPLIED BY THE DISTRICT AT THE OWNER'S EXPENSE AND INSTALLED BY THE OWNER.
- 7. PVC PIPELINES SHALL BE CONNECTED TO STRUCTURES WITH A MORRIL INDUSTRIES GALV. STEEL STARTER COUPLING. STARTER COUPLING SHALL BE CAST INTO THE STRUCTURE.

- 8. WALL OPENINGS SHALL BE REINFORCED WITH #6 BAR CIRCULAR RING AT OPENING DIA. +6" AND TIED TO WALL REINF.
- 9. THIS STANDARD DOES NOT APPLY TO MONOLITHIC CONCRETE PIPELINES. SEE DWG. NO. SD-8 FOR MONOLITHIC CONCRETE PIPE TURNOUTS.
- 10. TURNOUT BOX SHALL BE POURED IN PLACE AROUND THE (E) PIPELINE. PRE-CAST BOXES SHALL NOT BE ALLOWED W/O WRITTEN PERMISSION FROM THE DISTRICT.
- 11. THE OPEN FLOW METER SHALL BE OF-12D BY WATER SPECIALTIES. THE METER SHALL INDICATE IN CUBIC FEET PER SECOND AND TOTALIZE IN ACRE FEET. METER LENGTH SHALL BE SET SO THAT PROPELLER IS CENTERED IN THE PIPE AND THE METER HEAD IS READABLE FROM THE TOP OF THE BOX.
- 12. SEE DRAWING NO. SD-M-1 FOR BACKFILL REQUIREMENTS.
- 13. SEE DRAWING NO. SD-M-3 FOR RAILING AND LADDER REQUIREMENTS.



EXPLANATION OF SYMBOLS

- (E) EXISTING
- SDN SEE DRAWING NUMBER
- RGRCP RUBBER GASKET REINFORCED CONCRETE PIPE

PATTERSON IRRIGATION DISTRICT
PATTERSON CALIFORNIA

STANDARD DETAILS

PIPELINE TURNOUT INSTALLATION

SUMMERS ENGINEERING INC.
Consulting Engineers
HANFORD CALIFORNIA

DATE ---	APPROVED
DRAWN FJF	DRAWING NO. SD-T-4
CHECKED JCL	SHEET 12 OF 19
DRAWING NAME : PID 20011.DWG	

PATTERSON IRRIGATION DISTRICT	
APPROVED _____	DATE _____

*UNLESS DIRECTED OTHERWISE BY THE DISTRICT

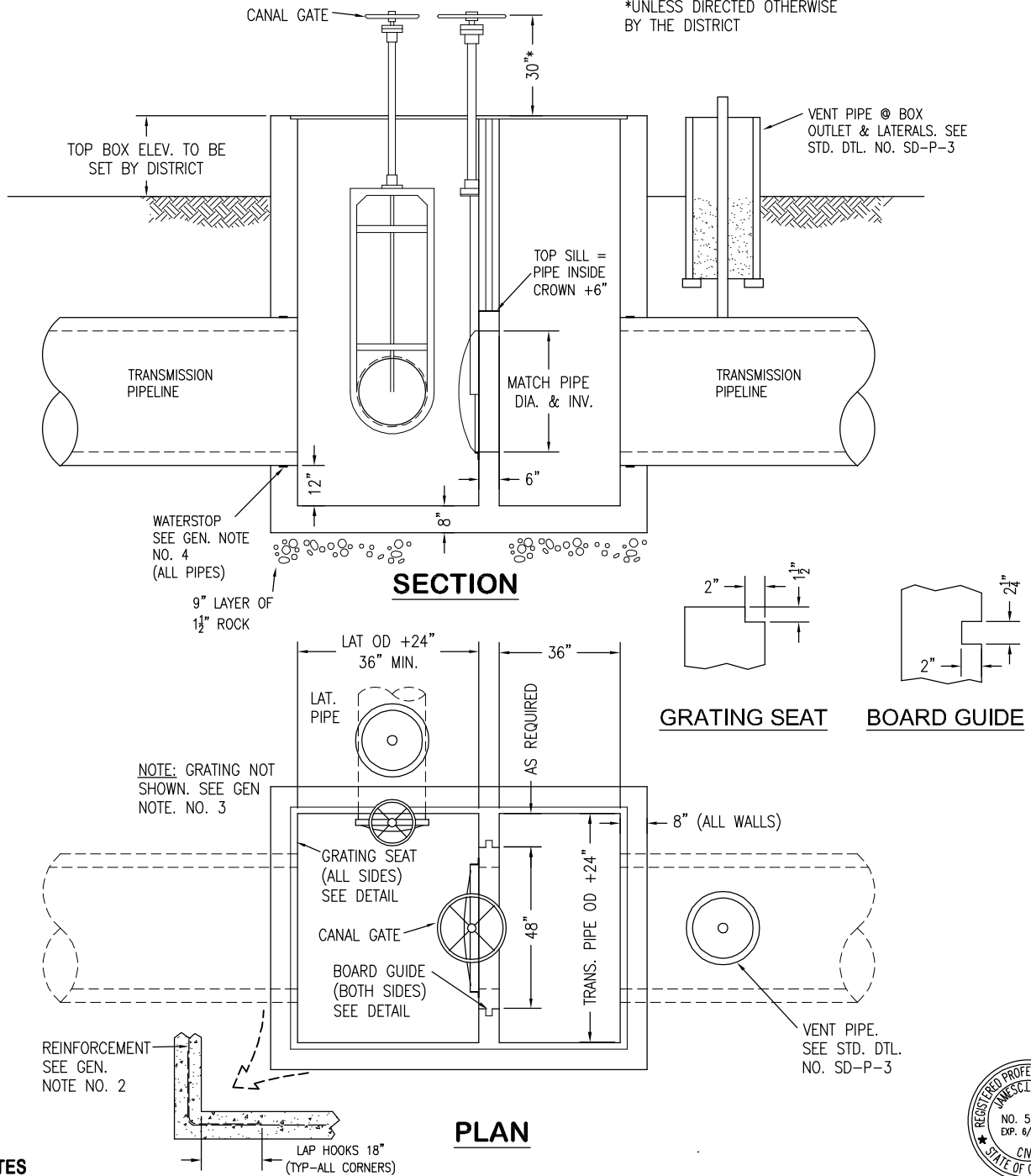

GENERAL NOTES

- 1. REINFORCED CONCRETE SHALL DEVELOP A MINIMUM COMPRESSIVE STRENGTH OF 4000 PSI. CEMENT SHALL BE TYPE II IN ACCORDANCE WITH ASTM C-150. A MINIMUM OF 6 SACKS OF CEMENT TO EACH CUBIC YARD OF CONCRETE SHALL BE USED.
- 2. REINF. SHALL BE #5@12" E.W. PLACED IN CTR OF WALLS. ALL REINFORCING BARS SHALL BE GRADE 60, CONFORMING TO ASTM A-615 OR A-706. ALL REINFORCING BAR BENDS SHALL HAVE A MINIMUM RADIUS OF FOUR BAR DIAMETERS AND SPLICES SHALL BE LAPPED FORTY BAR DIAMETERS.
- 3. GRATING (NOT SHOWN) SHALL BE 19-W-4 W/1 1/2" BEARING BARS BY GRATING PACIFIC OR APPROVED EQUAL. GRATING SHALL BE GALVANIZED W/ BANDED ENDS. SLOTS FOR GATE FRAMES AND METER SHALL BE PRECUT W/ 1" CLEARANCE ON ALL SIDES.
- 4. WATERSTOP SHALL BE SIKA HYDROTITE HYDROPHALIC PLACED AROUND OUTSIDE OF ALL PENETRATING PIPES & AT ALL COLD JOINTS.
- 5. SUBGRADE TO BE COMPACTED TO 90% MAX DRY DENSITY PER ASTM D-1557 PRIOR TO PLACEMENT OF ROCK.
- 6. SEE STANDARD DETAIL NO. SD-M-1 FOR BACKFILL REQUIREMENTS.

- 7. CANAL GATES SHALL BE SUPPLIED & INSTALLED BY THE DISTRICT AT THE OWNER'S EXPENSE. CANAL GATES SHALL BE 101-C BY FRESNO VALVES & CASTINGS.
- 8. PVC PIPE LATERALS SHALL BE CONNECTED TO CONTROL STRUCTURES WITH A MORRIL INDUSTRIES GALV. STEEL STARTER COUPLING. STARTER COUPLING SHALL BE CAST INTO THE CONTROL BOX.
- 9. WALL OPENINGS SHALL BE REINFORCED WITH #6 BAR CIRCULAR RING AT OPENING DIA. +6" AND TIED TO WALL REINF.
- 10. SEE DWG. NO. SD-P-1 AND SD-P-2 FOR CONNECTION BLOCKS AS REQUIRED.
- 11. CONTROL BOX MAX. DEPTH UNDER THIS STANDARD SHALL NOT EXCEED 10 FEET BELOW GROUND NOR 6 FEET ABOVE GROUND. SEE SD-6 FOR LARGE CONTROL BOX REQUIREMENTS.
- 12. PROVIDE RAILING & LADDERS TO ALL CONTROL BOXES THAT EXTEND 2' OR MORE ABOVE GRADE. SEE DWG. NO. SD-M-3

EXPLANATION OF SYMBOLS

- (E) EXISTING
- SDN SEE DRAWING NUMBER
- RGRCP RUBBER GASKET REINFORCED CONCRETE PIPE



PATTERSON IRRIGATION DISTRICT PATTERSON CALIFORNIA	
STANDARD DETAILS	
STANDARD PIPELINE CONTROL BOX	
SUMMERS ENGINEERING INC. HANFORD Consulting Engineers CALIFORNIA	
DATE: --- DRAWN: FJF CHECKED: JCL	APPROVED: DRAWING NO. SD-S-1 SHEET 13 OF 19
DRAWING NAME: PID 20011.DWG	

PATTERSON IRRIGATION DISTRICT	
APPROVED: _____	DATE: _____

GENERAL NOTES

- 1. REINFORCED CONCRETE SHALL DEVELOP A MINIMUM COMPRESSIVE STRENGTH OF 4000 PSI. CEMENT SHALL BE TYPE II IN ACCORDANCE WITH ASTM C-150. A MINIMUM OF 6 SACKS OF CEMENT TO EACH CUBIC YARD OF CONCRETE SHALL BE USED.
- 2. ALL REINFORCING BARS SHALL BE GRADE 60, CONFORMING TO ASTM A-615 OR A-706. ALL REINFORCING BAR BENDS SHALL HAVE A MINIMUM RADIUS OF FOUR BAR DIAMETERS AND SPLICES SHALL BE LAPPED FORTY BAR DIAMETERS.
- 3. CONTROL BOXES EXCEEDING ANY OF THE DIMENSIONS LIMITS SHOWN REQUIRE ANALYSIS BY A LICENSED ENGINEER AND APPROVAL FROM THE DISTRICT.
- 4. GRATING (NOT SHOWN) SHALL BE 19-W-4 W/ 1 1/2" BEARING BARS BY GRATING PACIFIC OR APPROVED EQUAL. GRATING SHALL BE GALVANIZED W/ BANDED ENDS. SLOTS FOR GATE FRAMES AND METER SHALL BE PRECUT W/ 1" CLEARANCE ON ALL SIDES.
- 5. WATERSTOP SHALL BE SIKA HYDROTITE HYDROPHALIC PLACED AROUND OUTSIDE OF ALL PENETRATING PIPES & AT ALL COLD JOINTS.
- 6. SUBGRADE TO BE COMPACTED TO 90% MAX DRY DENSITY PER ASTM D-1557 PRIOR TO PLACEMENT OF ROCK.
- 7. CANAL GATES SHALL BE SUPPLIED & INSTALLED BY THE DISTRICT AT THE OWNER'S EXPENSE.
- 8. PVC PIPE LATERALS SHALL BE CONNECTED TO CONTROL STRUCTURES WITH A MORRIL INDUSTRIES GALV. STEEL STARTER COUPLING. STARTER COUPLING SHALL BE CAST INTO THE CONTROL BOX.
- 9. LADDERS AND RAILING ARE REQUIRED. SEE DWG. NO SD-M-3.
- 10. SEE DRAWING NO. SD-M-1 FOR BACKFILL REQUIREMENTS.
- 11. SEE DRAWING NO. SD-P-1 AND SD-P-2 FOR CONNECTION BLOCK DETAILS AS REQUIRED.

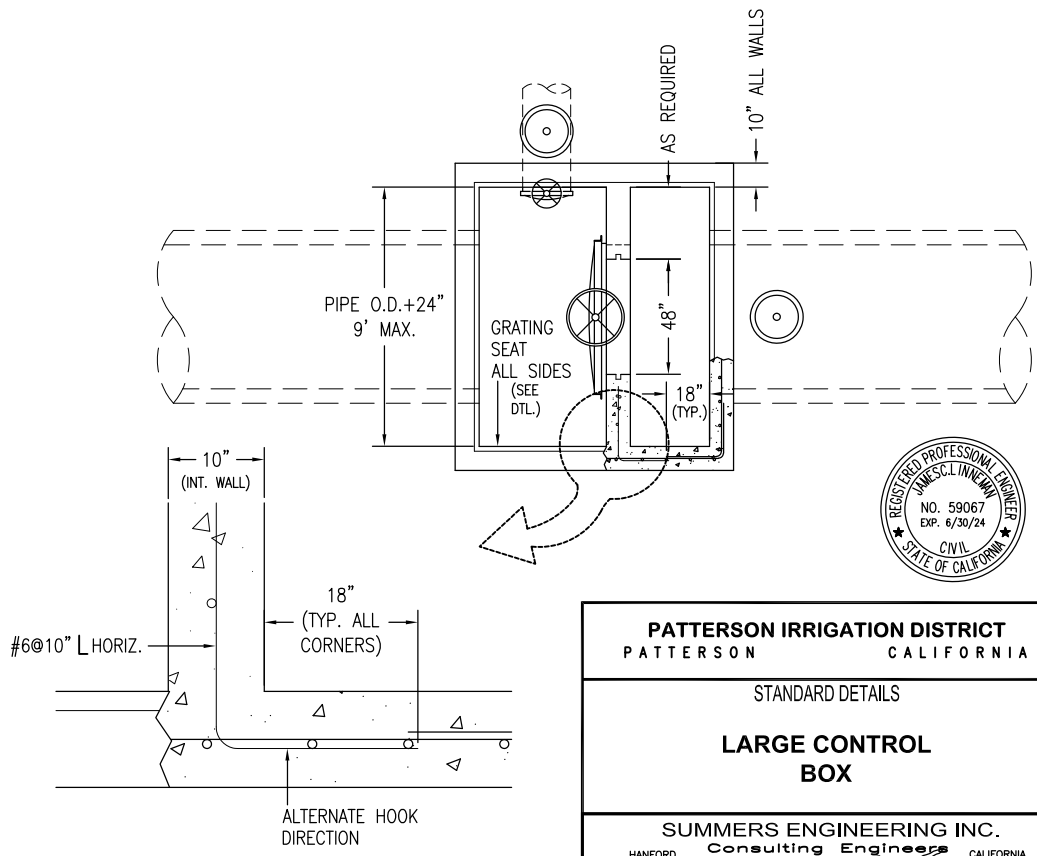
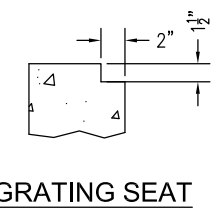
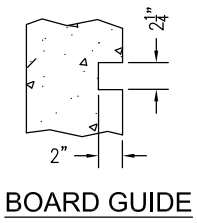
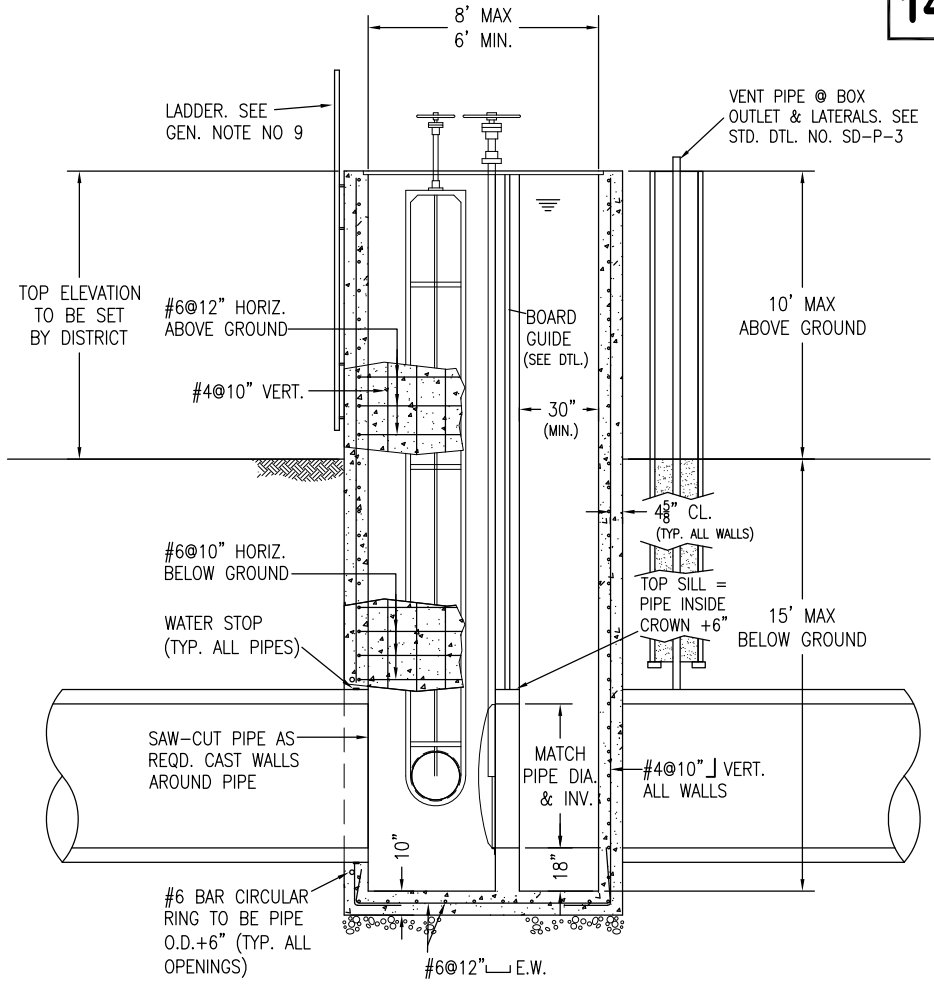

EXPLANATION OF SYMBOLS

- (E) EXISTING
- SDN SEE DRAWING NUMBER
- RGRCP RUBBER GASKET REINFORCED CONCRETE PIPE

PATTERSON IRRIGATION DISTRICT
PATTERSON CALIFORNIA

STANDARD DETAILS

LARGE CONTROL BOX

SUMMERS ENGINEERING INC.
Consulting Engineers CALIFORNIA

PATTERSON IRRIGATION DISTRICT		DATE	APPROVED
APPROVED	DATE	DRAWN FJF	DRAWING NO. SD-5-2
CHECKED JCL	DATE	CHECKED JCL	SHEET 14 OF 19
DRAWING NAME : PID 20011.DWG			

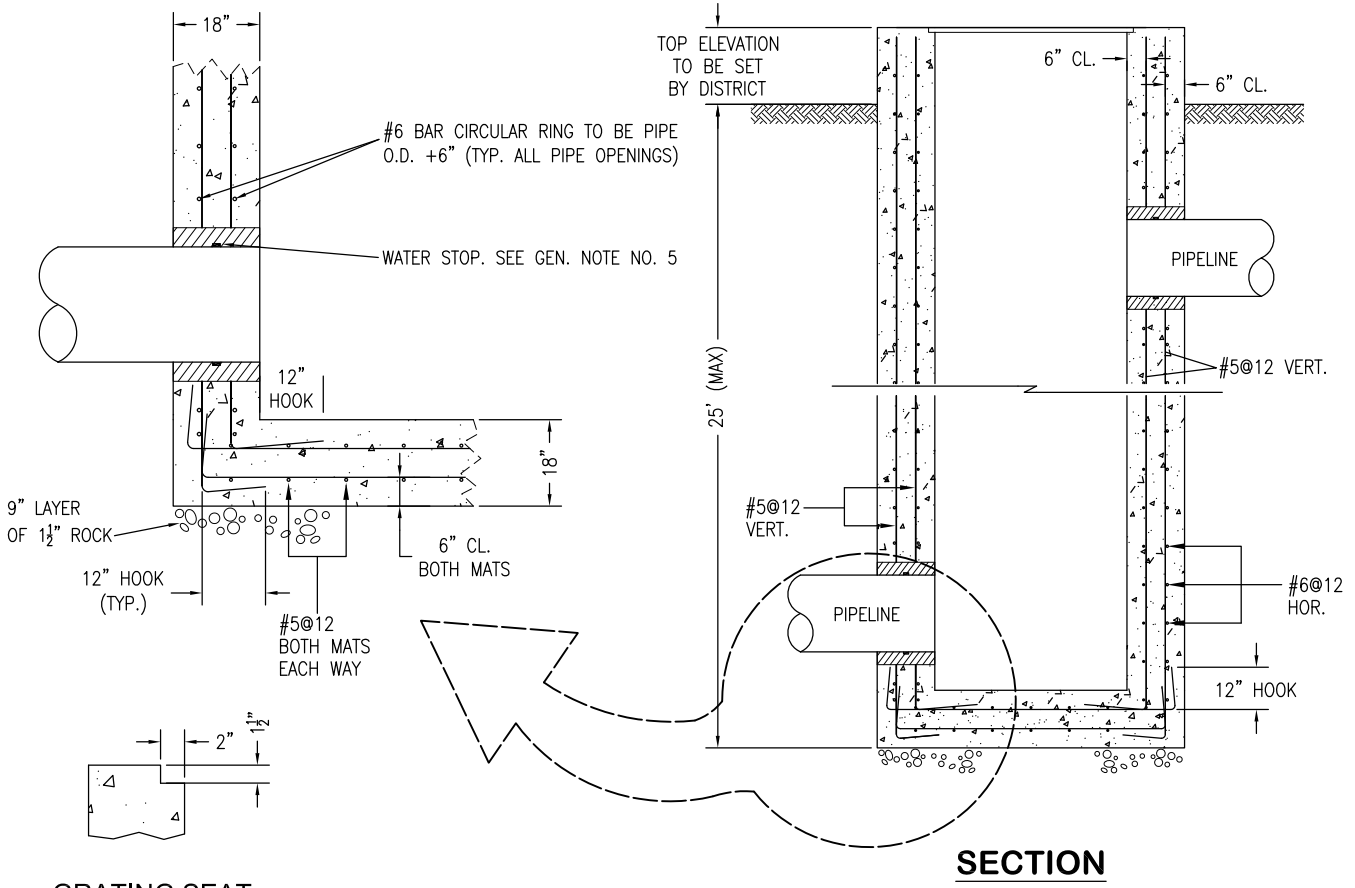

SECTION

GRATING SEAT

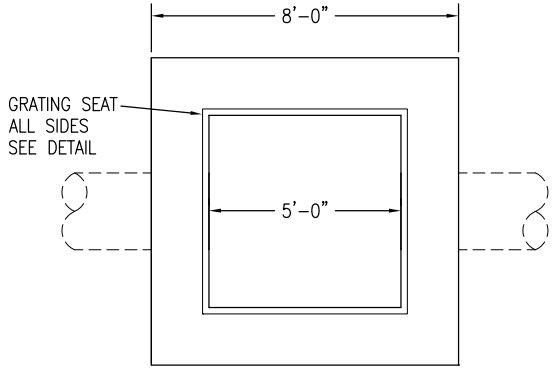

PLAN

GENERAL NOTES

- 1. REINFORCED CONCRETE SHALL DEVELOP A MINIMUM COMPRESSIVE STRENGTH OF 4000 PSI. CEMENT SHALL BE TYPE II IN ACCORDANCE WITH ASTM C-150. A MINIMUM OF 6 SACKS OF CEMENT TO EACH CUBIC YARD OF CONCRETE SHALL BE USED.
- 2. ALL REINFORCING BARS SHALL BE GRADE 60, CONFORMING TO ASTM A-615 OR A-706. ALL REINFORCING BAR BENDS SHALL HAVE A MINIMUM RADIUS OF FOUR BAR DIAMETERS AND SPLICES SHALL BE LAPPED FORTY BAR DIAMETERS.
- 3. STRUCTURES EXCEEDING ANY OF THE DIMENSIONS LIMITS SHOWN REQUIRE ANALYSIS BY A LICENSED ENGINEER AND APPROVAL FROM THE DISTRICT.
- 4. GRATING (NOT SHOWN) SHALL BE 19-W-4 W/ 1 1/2" BEARING BARS BY GRATING PACIFIC OR APPROVED EQUAL. GRATING SHALL BE GALVANIZED W/ BANDED ENDS. SLOTS FOR GATE FRAMES AND METER SHALL BE PRECUT W/ 1" CLEARANCE ON ALL SIDES.
- 5. WATERSTOP SHALL BE SIKA HYDROTITE HYDROPHALIC PLACED AROUND OUTSIDE OF ALL PENETRATING PIPES & AT ALL COLD JOINTS.
- 6. SUBGRADE TO BE COMPACTED TO 90% MAX DRY DENSITY PER ASTM D-1557 PRIOR TO PLACEMENT OF ROCK SDN SD-M-1.
- 7. CANAL GATES SHALL BE SUPPLIED & INSTALLED BY THE DISTRICT AT THE OWNER'S EXPENSE.
- 8. SEE DWG. NO. SD-P-1 OR SD-P-2 FOR CONNECTION DETAILS.
- 9. PROVIDE RAILING & LADDERS TO ALL CONTROL BOXES THAT EXTEND 2' OR MORE ABOVE GRADE. SEE DWG. NO. SD-M-3.

EXPLANATION OF SYMBOLS

- (E) EXISTING
- SDN SEE DRAWING NUMBER
- RGRCP RUBBER GASKET REINFORCED CONCRETE PIPE



PATTERSON IRRIGATION DISTRICT PATTERSON CALIFORNIA	
STANDARD DETAILS	
DEEP BOX DETAILS	
SUMMERS ENGINEERING INC. HANFORD Consulting Engineers CALIFORNIA	
DATE: AUG 2023	APPROVED:
DRAWN: NV	DRAWING NO. SD-S-3
CHECKED: JCL	SHEET 15 OF 19
DRAWING NAME: PID 20011.DWG	

PATTERSON IRRIGATION DISTRICT	
APPROVED: _____	DATE: _____

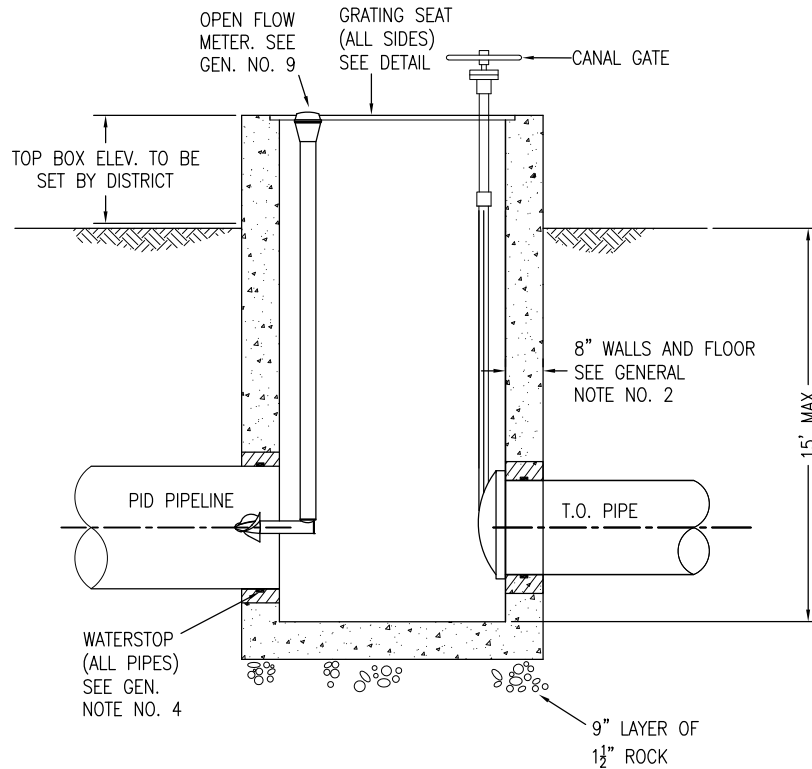

GRATING SEAT

NOTE: GRATING NOT SHOWN. SEE GEN NOTE. NO. 3

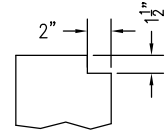

SECTION

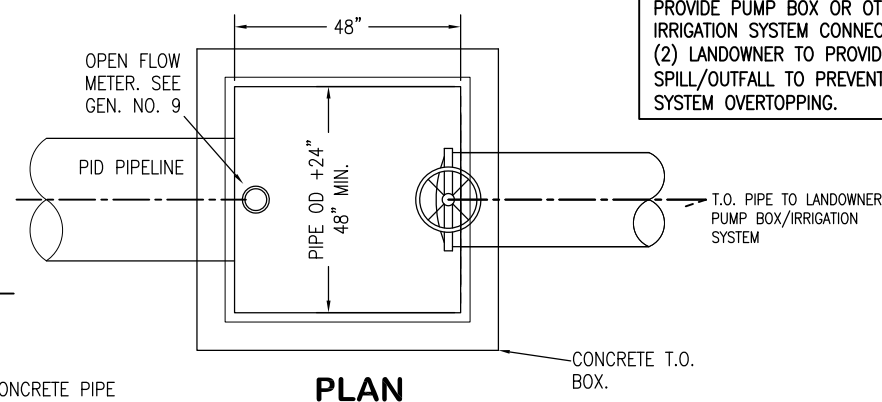

NOTE: (1) LANDOWNER TO PROVIDE PUMP BOX OR OTHER IRRIGATION SYSTEM CONNECTION. (2) LANDOWNER TO PROVIDE SPILL/OUTFALL TO PREVENT SYSTEM OVERTOPPING.

PLAN

EXPLANATION OF SYMBOLS

- (E) EXISTING
- SDN SEE DRAWING NUMBER
- RGRCP RUBBER GASKET REINFORCED CONCRETE PIPE

GENERAL NOTES

- 1. REINFORCED CONCRETE SHALL DEVELOP A MINIMUM COMPRESSIVE STRENGTH OF 4000 PSI. CEMENT SHALL BE TYPE II IN ACCORDANCE WITH ASTM C-150. A MINIMUM OF 6 SACKS OF CEMENT TO EACH CUBIC YARD OF CONCRETE SHALL BE USED.
- 2. REINF. SHALL BE #5@12" E.W. PLACED IN CTR OF WALLS. ALL REINFORCING BARS SHALL BE GRADE 60, CONFORMING TO ASTM A-615 OR A-706. ALL REINFORCING BAR BENDS SHALL HAVE A MINIMUM RADIUS OF FOUR BAR DIAMETERS AND SPLICES SHALL BE LAPPED FORTY BAR DIAMETERS.
- 3. GRATING (NOT SHOWN) SHALL BE 19-W-4 W/ 1 1/2" BEARING BARS BY GRATING PACIFIC OR APPROVED EQUAL. GRATING SHALL BE GALVANIZED W/ BANDED ENDS. SLOTS FOR GATE FRAMES SHALL BE PRECUT W/ 1" CLEARANCE ON ALL SIDES.
- 4. WATERSTOP SHALL BE SIKA HYDROTITE HYDROPHALIC PLACED AROUND OUTSIDE OF ALL PENETRATING PIPES & COLD JOINTS.
- 5. SUBGRADE TO BE COMPACTED TO 90% MAX DRY DENSITY PER ASTM D-1557 PRIOR TO PLACEMENT OF ROCK.
- 6. CANAL GATES SHALL BE SUPPLIED BY THE DISTRICT AT THE OWNER'S EXPENSE AND INSTALLED BY THE OWNER.
- 7. PVC PIPE LATERALS SHALL BE CONNECTED TO CONTROL STRUCTURES WITH A MORRIL INDUSTRIES GALV. STEEL STARTER COUPLING. STARTER COUPLING SHALL BE CAST INTO THE CONTROL BOX.
- 8. WALL OPENINGS SHALL BE REINFORCED WITH #6 BAR CIRCULAR RING AT OPENING DIA. +6" AND TIED TO WALL REINF.
- 9. THE OPEN FLOW METER SHALL BE OF-12D BY WATER SPECIALTIES. THE METER SHALL INDICATE IN CUBIC FEET PER SECOND AND TOTALIZE IN ACRE FEET. METER LENGTH SHALL BE SET SO THAT PROPELLER IS CENTERED IN THE PIPE AND THE METER HEAD IS READABLE FROM THE TOP OF THE BOX.
- 10. IF (E) PIPELINE IS 24" OR SMALLER, TURNOUT BOX TYPE I OR II MAY BE USED. SEE DWG. NO. SD-T-1 & SD-T-2.
- 11. SEE DWG. NO. SD-M-1 FOR BACKFILL REQUIREMENTS.
- 12. PROVIDE RAILING & LADDERS TO ALL BOXES THAT EXTEND 2' OR MORE ABOVE GRADE. SEE DWG. NO. SD-M-3
- 13. BOXES EXCEEDING ANY OF THE DIMENSIONS LIMITS SHOWN REQUIRE ANALYSIS BY A LICENSED ENGINEER AND APPROVAL FROM THE DISTRICT.

SPECIAL NOTE: THIS DETAIL APPLIES ONLY TO TURNOUTS AT THE END OF A PIPELINE.



PATTERSON IRRIGATION DISTRICT
PATTERSON CALIFORNIA

STANDARD DETAILS

**END OF PIPELINE TURNOUT
INSTALLATION**

SUMMERS ENGINEERING INC.
HANFORD Consulting Engineers CALIFORNIA

DATE: ---	APPROVED:
DRAWN: FJF	DRAWING NO. SD-S-4
CHECKED: JCL	SHEET 16 OF 19
DRAWING NAME: PID 20011.DWG	

PATTERSON IRRIGATION DISTRICT

APPROVED: _____

DATE: _____

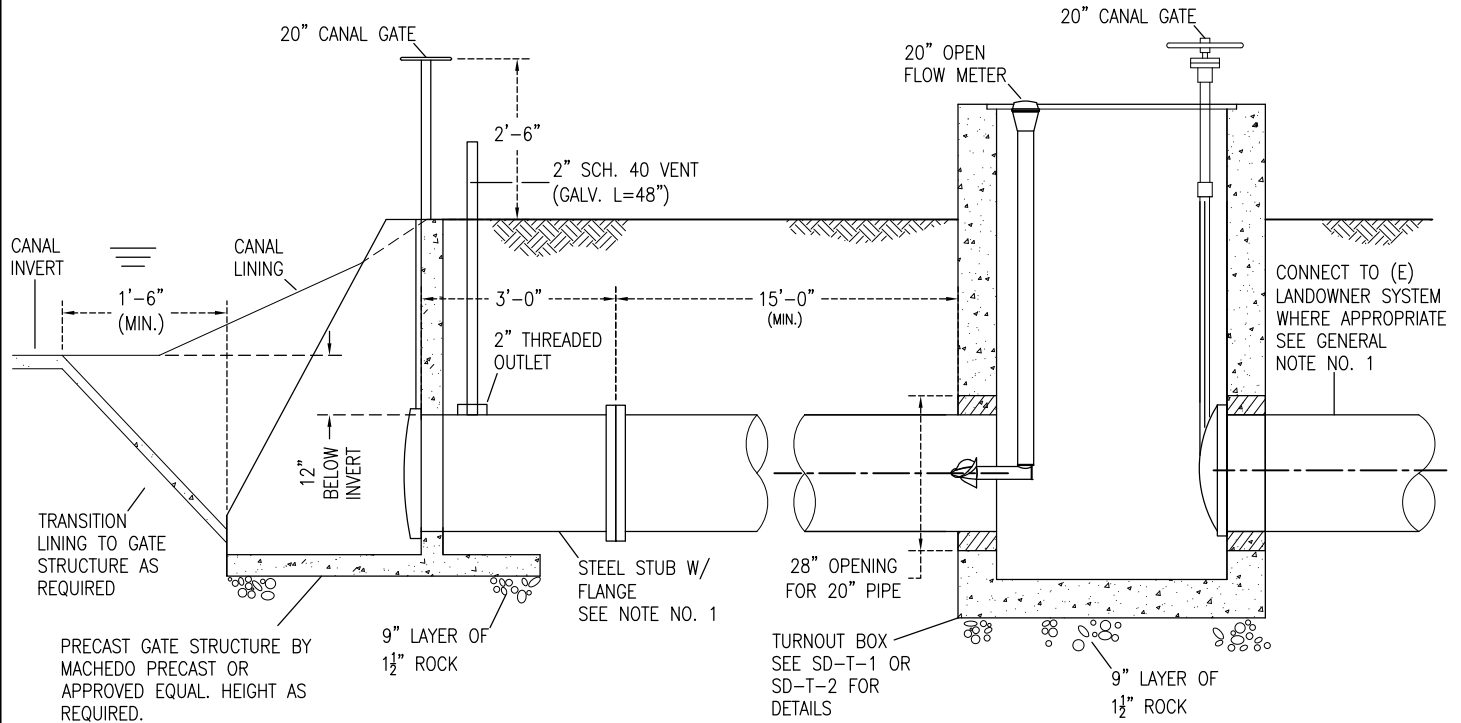

CANAL TURNOUT DETAIL

GENERAL NOTES

- 1. TURNOUT METER BOXES SHALL BE CONNECTED TO (E) LANDOWNER IRRIGATION SYSTEMS. CONTRACTOR SHALL MATCH THE EXISTING SYSTEM PIPE MATERIAL AND DIMENSIONS. WHERE METER BOX CONNECTIONS ARE BELOW GROUND, THE DISTRICT SHALL PROVIDE CANAL GATES FOR THE CONTRACTOR TO INSTALL.
- 2. LANDOWNER TO PROVIDE FLOW METER. OPEN FLOW METER SHALL BE OF-12 BY WATER SPECIALTIES OR APPROVED EQUAL. THE METER SHALL INDICATE IN CUBIC FEET PER SECOND AND TOTALIZE IN ACRE FEET.
- 3. ALL CONNECTIONS TO STRUCTURES SHALL BE WATER-TIGHT.
- 4. ALL STEEL PIPE AND FITTINGS SHALL BE IN ACCORDANCE WITH AWWA C-200 (1/4" WALL, MINIMUM). ALL STEEL FLANGES SHALL BE IN ACCORDANCE WITH AWWA C-207, CLASS D. ALL PIPES, FLANGES, AND MECHANICAL COUPLINGS SHALL BE FUSION BONDED EPOXY LINED AND COATED (12 MILS MIN.) IN ACCORDANCE WITH AWWA C-213 AND ENCASED IN A POLYETHYLENE BAG.
- 5. REPLACEMENT CONCRETE LINING SHALL DEVELOP MINIMUM COMPRESSIVE STRENGTH OF 3000 PSI. A MINIMUM OF 5 1/2 SACKS OF CEMENT TO EACH CUBIC YARD OF CONCRETE SHALL BE USED. CEMENT SHALL BE TYPE II AND CONFORM TO ASTM C-150. THE MAXIMUM NOMINAL SIZE OF THE COARSE AGGREGATE SHALL BE 3/4". NOVAMESH 950, NYCONXL OR APPROVED EQUAL SHALL BE ADDED TO EACH CUBIC YARD OF CONCRETE AT THE RATE RECOMMENDED BY THE MANUFACTURER. REPLACEMENT CONCRETE LINING SHALL BE 3" THICK, MINIMUM.
- 6. COMPACT SUBGRADE TO 90% MAX. DRY DENSITY PER ASTM D-1557 PRIOR TO THE PLACEMENT OF ROCK.
- 7. SEE STANDARD DETAIL NO. SD-M-1 FOR BACKFILL REQUIREMENTS.

EXPLANATION OF SYMBOLS

- (E) EXISTING
- SDN SEE DRAWING NUMBER
- RGRCP RUBBER GASKET REINFORCED CONCRETE PIPE



PATTERSON IRRIGATION DISTRICT PATTERSON CALIFORNIA	
STANDARD DETAILS	
CANAL TURNOUT DETAIL	
SUMMERS ENGINEERING INC. HANFORD Consulting Engineers CALIFORNIA	
DATE: --- DRAWN: FJF CHECKED: JCL DATE: _____	APPROVED: DRAWING NO. SD-C-1 SHEET 17 OF 19 DRAWING NAME: PID 20011.DWG

PATTERSON IRRIGATION DISTRICT	
APPROVED: _____	DATE: _____

GENERAL NOTES

- 1. PROVIDE ALL SHEETING, SHORING, BRACING, SLOPPING, OR OTHER METHODS FOR REQUIRED WORKER SAFETY AND PROTECTION.
- 2. REINFORCED CONCRETE SHALL DEVELOP A MINIMUM COMPRESSIVE STRENGTH OF 3000 PSI. CEMENT SHALL BE TYPE II IN ACCORDANCE WITH ASTM C-150. A MINIMUM OF 5 1/2 SACKS OF CEMENT TO EACH CUBIC YARD OF CONCRETE SHALL BE USED.
- 3. ALL REINFORCING BARS SHALL BE GRADE 60, CONFORMING TO ASTM A-615. ALL REINFORCING BAR BENDS SHALL HAVE A MINIMUM RADIUS OF FOUR BAR DIAMETERS AND SPLICES SHALL BE LAPPED FORTY BAR DIAMETERS.
- 4. CHAMFER ALL EXPOSED CORNERS OF CONCRETE 1"±. HAUNCH ALL INTERIOR CORNERS OF CONCRETE 1"± EXCEPT WHERE NOTED OTHERWISE.
- 5. SAW-CUT AND REMOVE EXISTING LINING AS REQUIRED. REPLACEMENT LINING SHALL BE 4" THICK (MIN.) AND REINFORCED WITH FIBER MESH (OR APPROVED EQUAL) TO MANUFACTURER'S STANDARDS.
- 6. WATER STOP SHALL BE SIKA HYDROTITE HYDROPHALIC PLACED AROUND OUTSIDE OF ALL PENETRATING PIPES.
- 7. SEE STANDARD DETAIL NO. SD-M-1 FOR BACKFILL REQUIREMENTS.

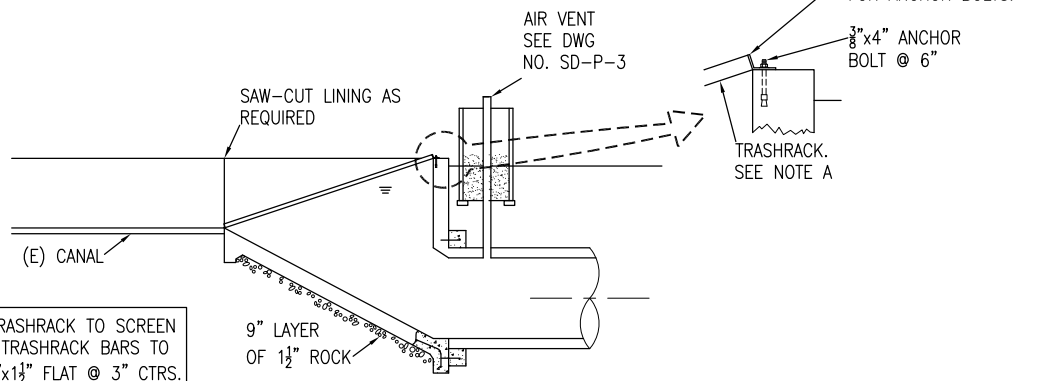
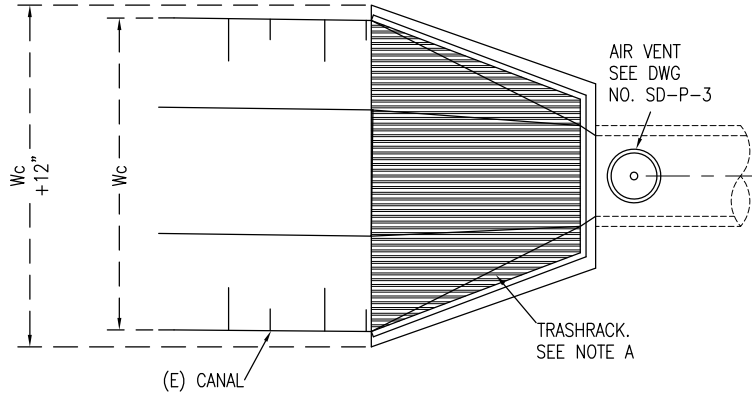

NOTE A: PROVIDE TRASHRACK TO SCREEN INLET TO PIPELINE. TRASHRACK BARS TO BE 1/2" ROUND OR 3/8" x 1 1/2" FLAT @ 3" CTRS. BARS TO BE WELDED TO STEEL FRAME AND ANCHORED TO TRANSITION STRUCTURE. TRASHRACK SHALL BE GALVANIZED AFTER FABRICATION.

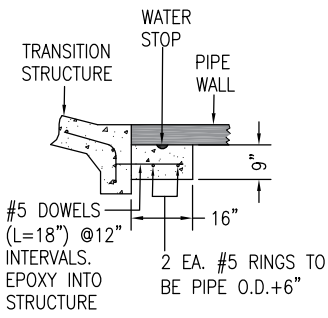

TRANSITION STRUCTURE

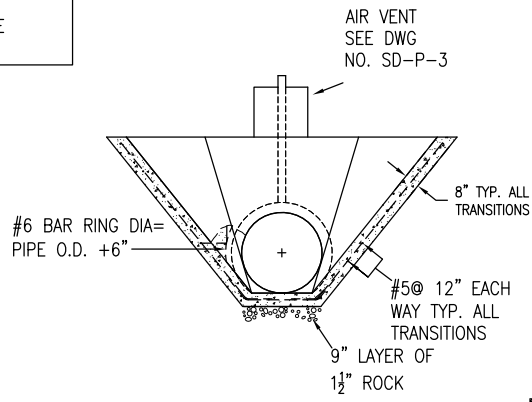

TRANSITION STRUCTURE DETAILS

EXPLANATION OF SYMBOLS

- (E) EXISTING
- SDN SEE DRAWING NUMBER
- RGRCP RUBBER GASKET REINFORCED CONCRETE PIPE



PATTERSON IRRIGATION DISTRICT
PATTERSON CALIFORNIA

STANDARD DETAILS

CANAL TO PIPELINE TRANSITION STRUCTURE

SUMMERS ENGINEERING INC.
HANFORD Consulting Engineers CALIFORNIA

PATTERSON IRRIGATION DISTRICT		DATE ---	APPROVED
APPROVED	DRAWN FJF	DRAWING NO. SD-C-2	
DATE	CHECKED JCL	SHEET 18 OF 19	
DRAWING NAME: PID 20011.DWG			

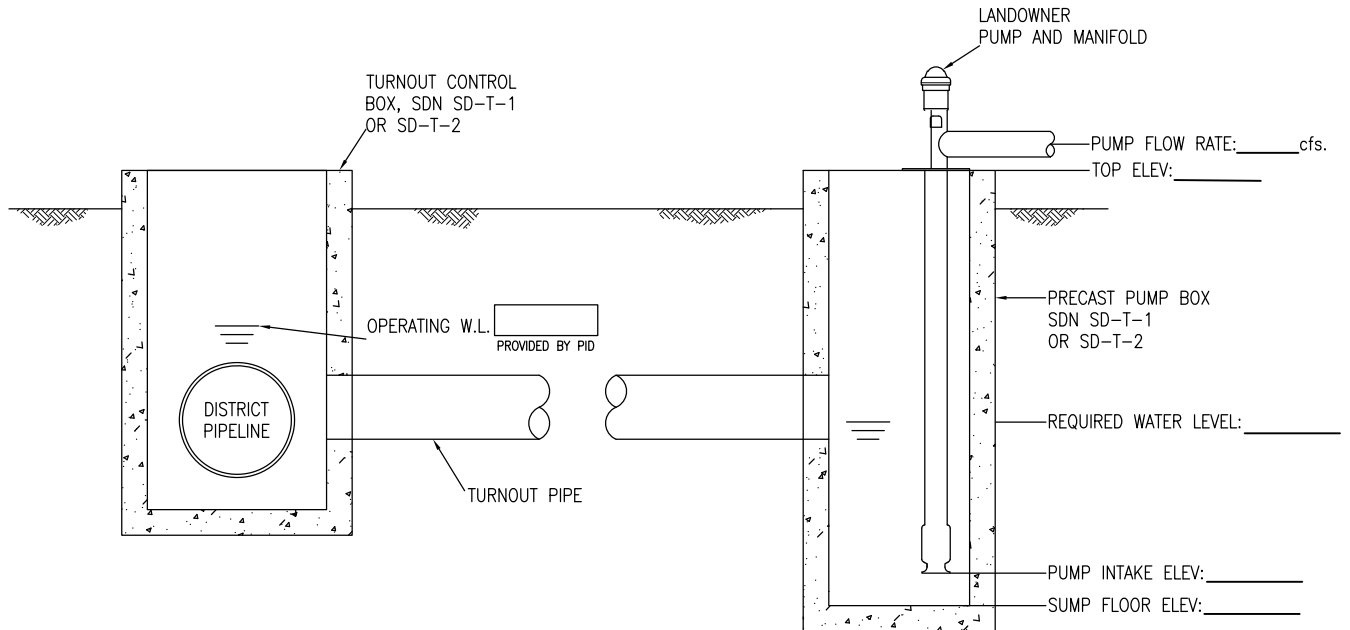

INSTRUCTIONS:

- 1. LANDOWNER SHALL COMPLETE AND SUBMIT THIS FORM TO PATTERSON IRRIGATION DISTRICT (PID) FOR APPROVAL.
- 2. PID SHALL PROVIDE THE OPERATING WATER LEVEL FOR THE SYSTEM.
- 3. THE LANDOWNER SHALL PROVIDE THE TOP SUMP ELEVATION, THE REQUIRED WATER LEVEL TO PROVIDE SUFFICIENT PUMP SUBMERGENCE, AND INVERT ELEVATION.
- 4. THE LANDOWNER PUMP SHALL INCLUDE A FLOW METER THAT INDICATES IN CUBIC FEET PER SECOND (CFS) AND TOTALIZES IN ACER-FEET.
- 5. THE LANDOWNER IS RESPONSIBLE FOR THE ACCURACY OF ALL INDICATED ELEVATIONS AND PUMP DATA.
- 6. THE PUMP TURNOUT INSTALLATION SHALL CONFORM TO ALL APPLICABLE PID STANDARDS.

EXPLANATION OF SYMBOLS

- (E) EXISTING
- SDN SEE DRAWING NUMBER
- RGRCP RUBBER GASKET REINFORCED CONCRETE PIPE



PATTERSON IRRIGATION DISTRICT PATTERSON CALIFORNIA	
STANDARD DETAILS	
PUMP TURNOUT APPLICATION	
SUMMERS ENGINEERING INC. HANFORD Consulting Engineers CALIFORNIA	
DATE: ---	APPROVED:
DRAWN: NV	DRAWING NO. SD-A-1
CHECKED: JCL	SHEET 19 OF 19
DRAWING NAME: PID 20011.DWG	

PATTERSON IRRIGATION DISTRICT	
APPROVED: _____	DATE: _____

1. PROVIDE ALL SHEETING, SHORING, BRACING, SLOPING, OR OTHER METHODS REQUIRED FOR WORKER SAFETY AND PROTECTION.

2. THRUST BLOCKS SHALL BE REQUIRED ON ALL TEES AND BENDS GREATER THAN 5'.

3. ALL STEEL PIPE AND FITTINGS SHALL BE IN ACCORDANCE WITH AWWA C-200 (1/4" WALL, MINIMUM). ALL STEEL FLANGES SHALL BE IN ACCORDANCE WITH AWWA C-207, CLASS D. ALL PIPE, FLANGES, AND MECHANICAL COUPLINGS SHALL BE FUSION BONDED EPOXY LINED AND COATED (12 MILS MIN.) IN ACCORDANCE WITH AWWA C-213. ALL EXPOSED PIPE SHALL BE COATED WITH 2 OR MORE COATS OF HIGH SOLIDS EPOXY IN ACCORDANCE WITH AWWA C-210. EXTERIOR TOP COAT SHALL BE A COMPATIBLE ALPHATIC POLYURETHANE.

4. BURIED BUTTERFLY VALVES SHALL BE PRATT GROUNDHOG OR APPROVED EQUAL. BUTTERFLY VALVE INSTALLED ABOVE GROUND SURFACE SHALL BE MONOFLANGE MKII WAVER BUTTERFLY VALVE BY PRATT OR APPROVED EQUAL. ALL BUTTERFLY VALVES SHALL MEET THE APPLICABLE SPECIFICATIONS OF AWWA C504.

5. THE VERTICAL UPFLOW TEE METER SHALL BE MODEL VF30 BY WATER SPECIALTIES, OR APPROVED EQUAL. THE METER SHALL INDICATE IN CFS AND TOTALIZE IN ACRE FEET.

6. THE AIR RELEASE VALVE SHALL BE MODEL CR-101 BY WATERMAN INDUSTRIES OR APPROVED EQUAL.

7. THE TEE SHALL BE A STANDARD TEE CONNECTION OF SAME MATERIAL AND RATING OF THE TRANSMISSION PIPE OR TAPPING SLEEVE, AS REQUIRED BY THE DISTRICT. TAPPING SLEEVES SHALL BE MODEL SST III OR STS420 BY ROMAC OR APPROVED EQUAL. ALL NUTS BOLTS AND WASHERS SHALL BE STAINLESS.

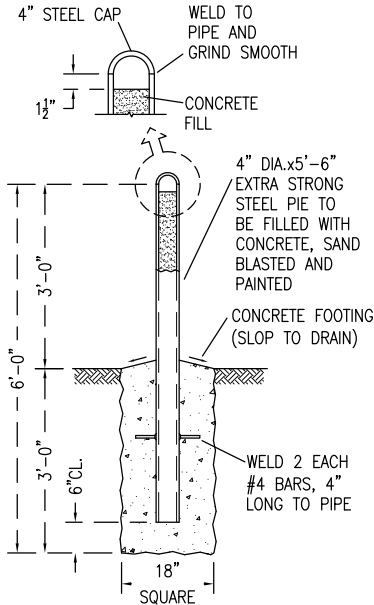
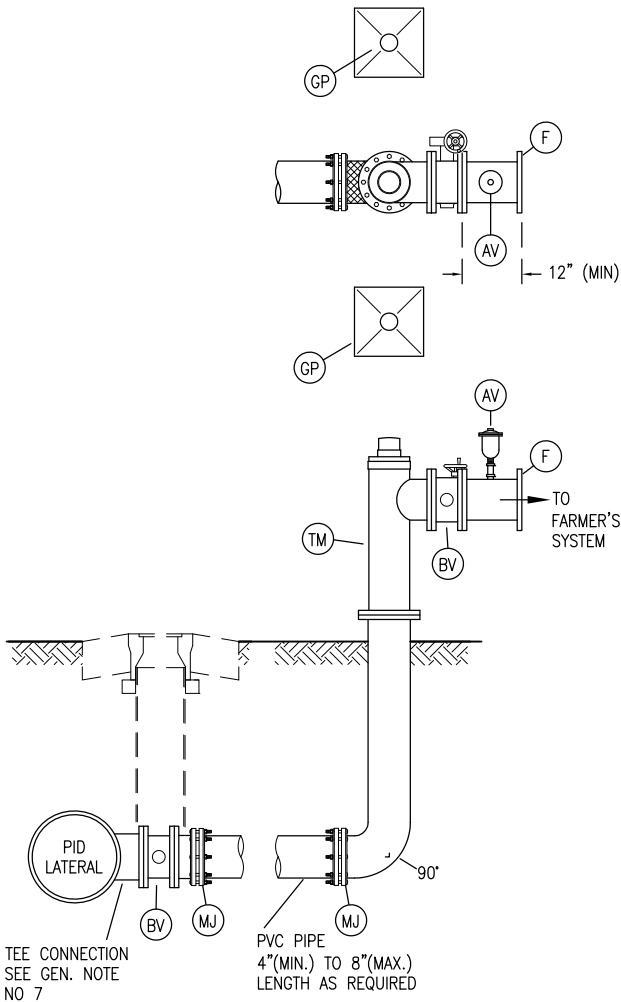

TYPICAL GUARD POST INSTALLATION (GP)

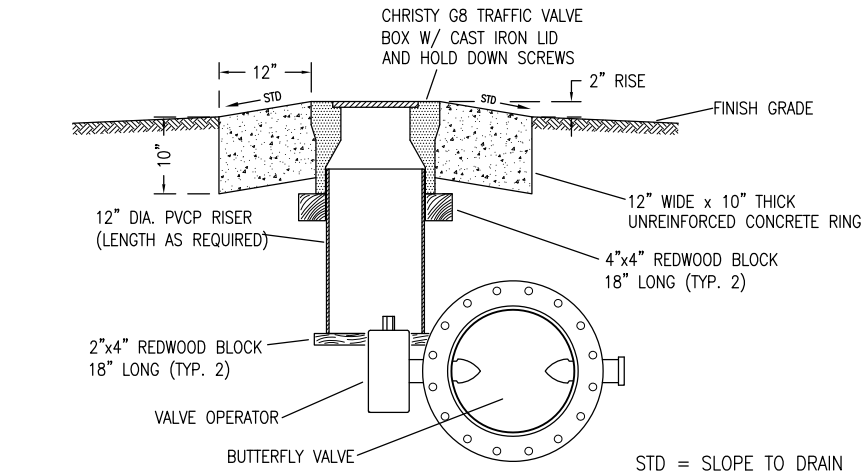

TYPICAL BUTTERFLY VALVE INSTALLATION (BV)

EXPLANATION OF SYMBOLS

- (AV) 1" AIR VALVE W/ NIPPLE AND HALF COUPLING
- (BV) BUTTERFLY VALVE INSTALLATION SEE DETAIL.
- (F) FLANGE. SEE GEN. NOTE NO. 3
- (GP) GUARD POST INSTALLATION SEE DETAIL.
- (MJ) MECHANICAL JOINT ADAPTOR
- (TM) TEE METER

PATTERSON IRRIGATION DISTRICT
PATTERSON CALIFORNIA

STANDARD DETAILS

FIRE HYDRANT
TURNOUT DETAIL

SUMMERS ENGINEERING INC.
Consulting Engineers

HANFORD CALIFORNIA



PATTERSON IRRIGATION DISTRICT	
APPROVED _____	DATE _____

DATE JUNE 2023	APPROVED <i>[Signature]</i>
DRAWN NV	DRAWING NO. SD-P-20
CHECKED JCL	SHEET 20 OF 20
DRAWING NAME : PID 20011.DWG	

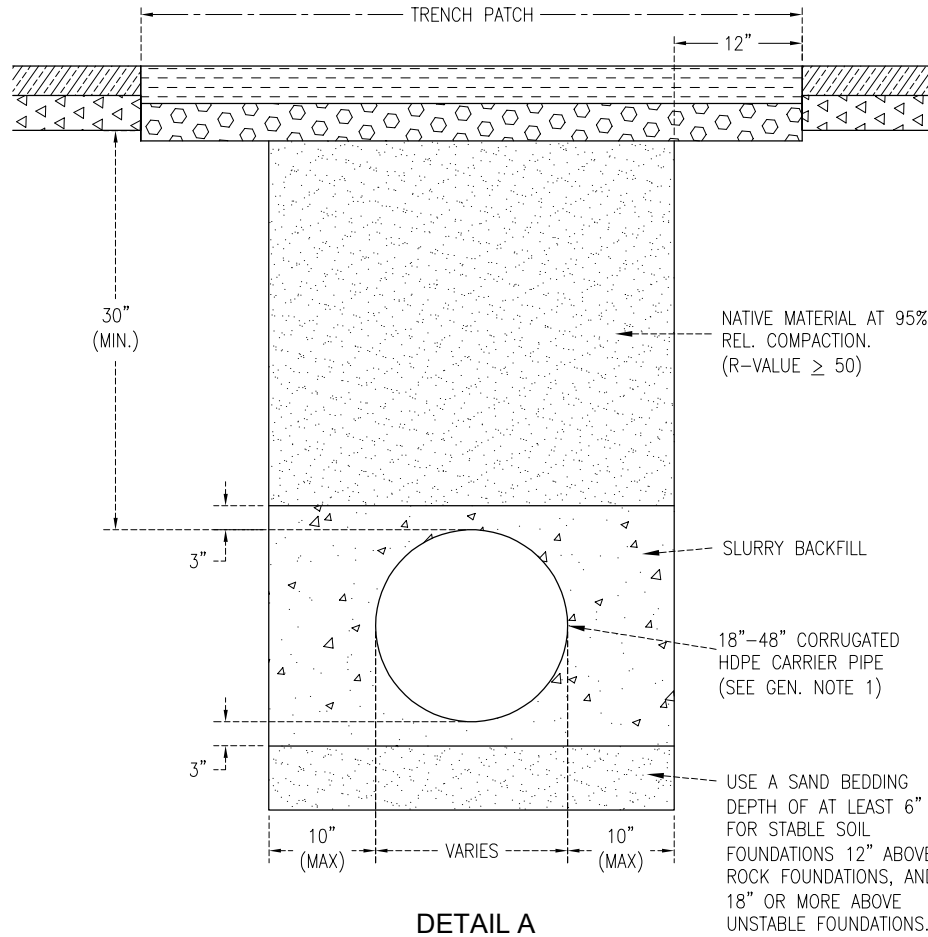

DETAIL A
BACKFILL DETAIL
PAVED AREAS

GENERAL NOTES

- █ 1. PIPE TO BE ADS N-12 DUAL WALL WTIB CORRUGATED HDPE PIPE OR APPROVED EQUIVALENT.
- █ 2. PROVIDE 95% COMPACTING IN 8" LAYERS FOR THE ENTIRE DEPTH OF TRENCH.
- █ 3. POUNDING OR JETTING WILL NOT BE ALLOWED.
- █ 4. IF SOIL R-VALUE IS LESS THAN 50, USE CLASS 2 AB VERSUS NATIVE MATERIAL.
- █ 5. COMPACTION TEST SHALL BE PERFORMED BY CONTRACTOR AND BE SUBMITTED TO (AND APPROVED) BY THE COUNTY INSPECTOR PRIOR TO PAVING, USING CALTRANS TEST METHOD NO. 216 AND NO. 231.
- █ 6. USE A PAVEMENT AND BASE THICKNESS OF AT LEAST 3" AND 6" RESPECTIVELY OR 1" THICKER THAN THE EXISTING A.C., WHICHEVER IS GREATER. PRIME COAT IS REQUIRED ABOVE AGGREGATE BASE.
- █ 7. PIPELINES WITHIN STANISLAUS COUNTY SHALL REQUIRE AN APPROVED ENCROACHMENT PERMIT FROM THE COUNTY.

EXPLANATION OF SYMBOLS

- (E) EXISTING
- SDN SEE DRAWING NUMBER
- RGRCP RUBBER GASKET REINFORCED CONCRETE PIPE



PATTERSON IRRIGATION DISTRICT PATTERSON CALIFORNIA	
STANDARD DETAILS	
HDPE PAVED AREA BACKFILL REQUIREMENTS	
SUMMERS ENGINEERING INC. HANFORD Consulting Engineers CALIFORNIA	
DATE FEB 2025	APPROVED
DRAWN FJF/NV/ARA	DRAWING NO. SD-M-21
CHECKED JCL	SHEET 21 OF 21
DRAWING NAME : PID 20011.DWG	

PATTERSON IRRIGATION DISTRICT	
APPROVED _____	DATE _____

GENERAL NOTES

- 1. PROVIDE ALL SHEETING, SHORING, BRACING, SLOPPING, OR OTHER METHODS FOR REQUIRED WORKER SAFETY AND PROTECTION.
- 2. REINFORCED CONCRETE SHALL DEVELOP A MINIMUM COMPRESSIVE STRENGTH OF 3000 PSI. CEMENT SHALL BE TYPE II IN ACCORDANCE WITH ASTM C-150. A MINIMUM OF 5 1/2 SACKS OF CEMENT TO EACH CUBIC YARD OF CONCRETE SHALL BE USED.
- 3. ALL REINFORCING BARS SHALL BE GRADE 60, CONFORMING TO ASTM A-706. ALL REINFORCING BAR BENDS SHALL HAVE A MINIMUM RADIUS OF FOUR BAR DIAMETERS AND SPLICES SHALL BE LAPPED FORTY BAR DIAMETERS.
- 4. CHAMFER ALL EXPOSED CORNERS OF CONCRETE 1"±. HAUNCH ALL INTERIOR CORNERS OF CONCRETE 1"± EXCEPT WHERE NOTED OTHERWISE.
- 5. SAW-CUT AND REMOVE EXISTING LINING AS REQUIRED. REPLACEMENT LINING SHALL BE 4" THICK (MIN.) AND REINFORCED WITH FIBER MESH (OR APPROVED EQUAL) TO MANUFACTURER'S STANDARDS.
- 6. WATER STOP SHALL BE SIKA HYDROTITE HYDROPHALIC PLACED AROUND OUTSIDE OF ALL PENETRATING PIPES.
- 7. SEE STANDARD DETAIL NO. SD-M-1 FOR BACKFILL REQUIREMENTS.
- 8. THIS STANDARD DETAIL ONLY APPLIES TO PIPE DIAMETERS OF 48" OR LOWER. FURTHER ENGINEERING SERVICES REQUIRED FOR LARGER DIAMETERS.

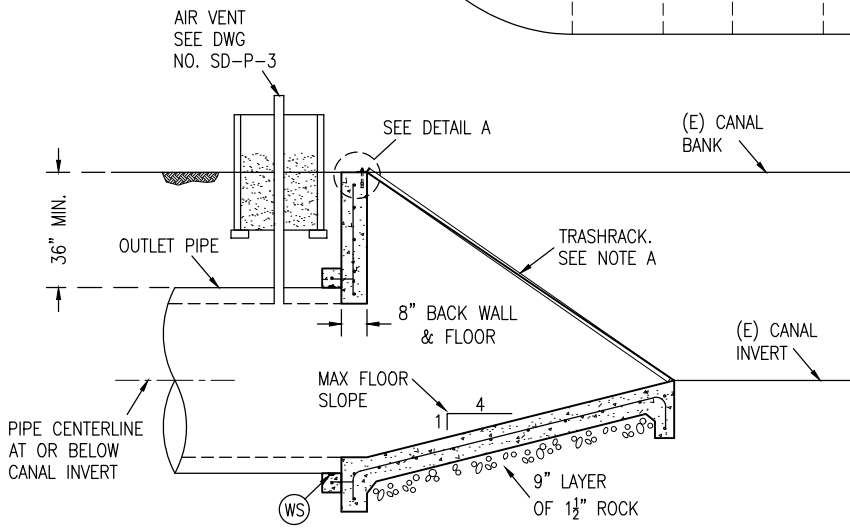
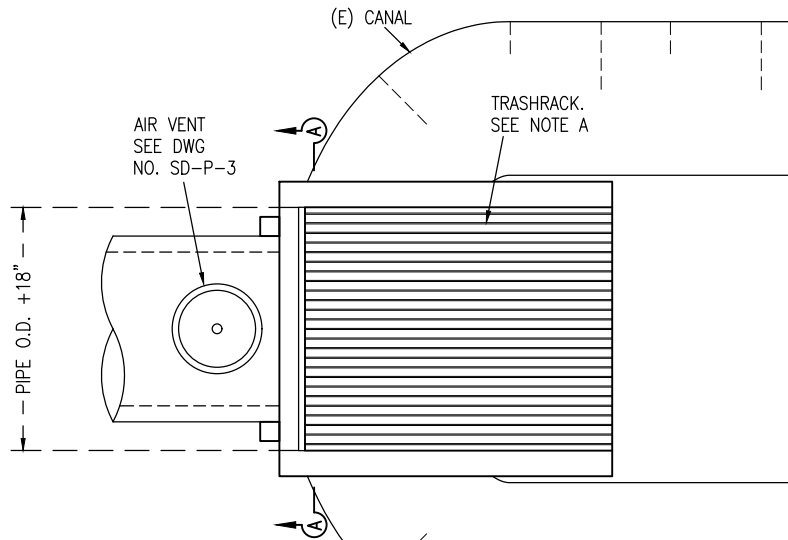

NOTE A: PROVIDE TRASHRACK TO SCREEN INLET TO PIPELINE. TRASHRACK BARS TO BE 3/4" ROUND OR 3/8"x1 1/2" FLAT @ 3" CTRS. BARS TO BE WELDED TO STEEL FRAME AND ANCHORED TO TRANSITION STRUCTURE. TRASHRACK SHALL BE GALVANIZED AFTER FABRICATION.

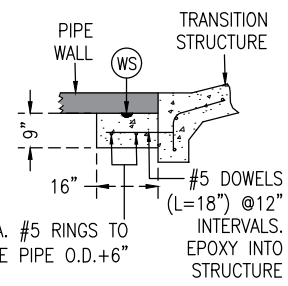
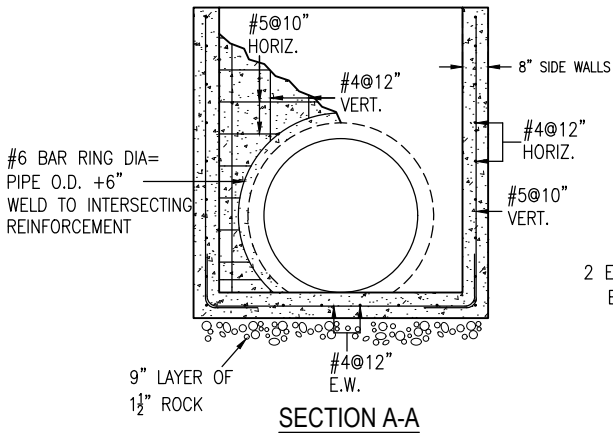

EXPLANATION OF SYMBOLS

- (E) EXISTING
- SDN SEE DRAWING NUMBER
- RGRCP RUBBER GASKET REINFORCED CONCRETE PIPE
- (WS) WATER STOP, SEE GENERAL NOTE NO. 6

SECTION A-A

TRANSITION STRUCTURE

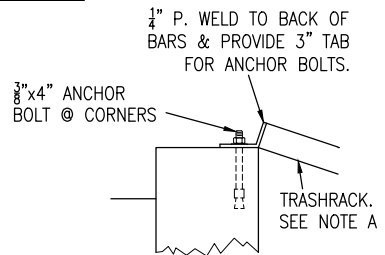

DETAIL A



PATTERSON IRRIGATION DISTRICT PATTERSON CALIFORNIA	
STANDARD DETAILS	
PIPELINE TO CANAL TRANSITION STRUCTURE	
SUMMERS ENGINEERING INC. Consulting Engineers HANFORD CALIFORNIA	
PATTERSON IRRIGATION DISTRICT APPROVED _____ DATE _____	DATE _____ DRAWN: ARA CHECKED: JCL DRAWING NO. SD-C-3 SHEET 22 OF 22 DRAWING NAME: PID 20011.DWG

GENERAL NOTES

- 1. PROVIDE ALL SHEETING, SHORING, BRACING, SLOPPING, OR OTHER METHODS FOR REQUIRED WORKER SAFETY AND PROTECTION.
- 2. ALL CONCRETE LINING SHALL DEVELOP A MINIMUM COMPRESSIVE STRENGTH OF 3,000 PSI. A MINIMUM OF 5½ SACKS OF CEMENT TO EACH CUBIC YARD OF CONCRETE SHALL BE USED. CEMENT SHALL BE TYPE II AND CONFORM TO ASTM C-150. THE MAXIMUM NOMINAL SIZE OF THE COURSE AGGREGATE SHALL BE ¾". NOVOMESH 950, NYCONXL OR APPROVED EQUAL SHALL BE ADDED TO EACH CUBIC YARD OF CONCRETE AT THE RATE RECOMMENDED BY THE MANUFACTURER.
- 3. THE CANAL PAD SHALL BE COMPACTED TO A MAXIMUM DRY DENSITY BETWEEN 85% AND 92% PER ASTM D-1557.
- 4. ALL REINFORCING BARS SHALL BE GRADE 60, CONFORMING TO ASTM A-706. ALL REINFORCING BAR BENDS SHALL HAVE A MINIMUM RADIUS OF FOUR BAR DIAMETERS AND SPLICES SHALL BE LAPPED FORTY BAR DIAMETERS.
- 5. ALL REINFORCING BARS TO BE PLACED IN THE CENTER OF THE LINING UNLESS OTHERWISE NOTED.

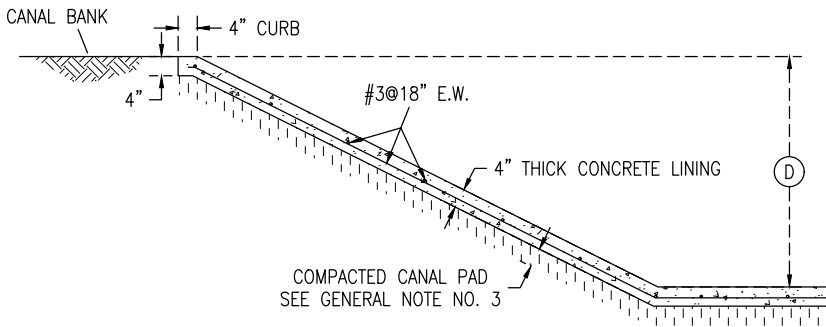
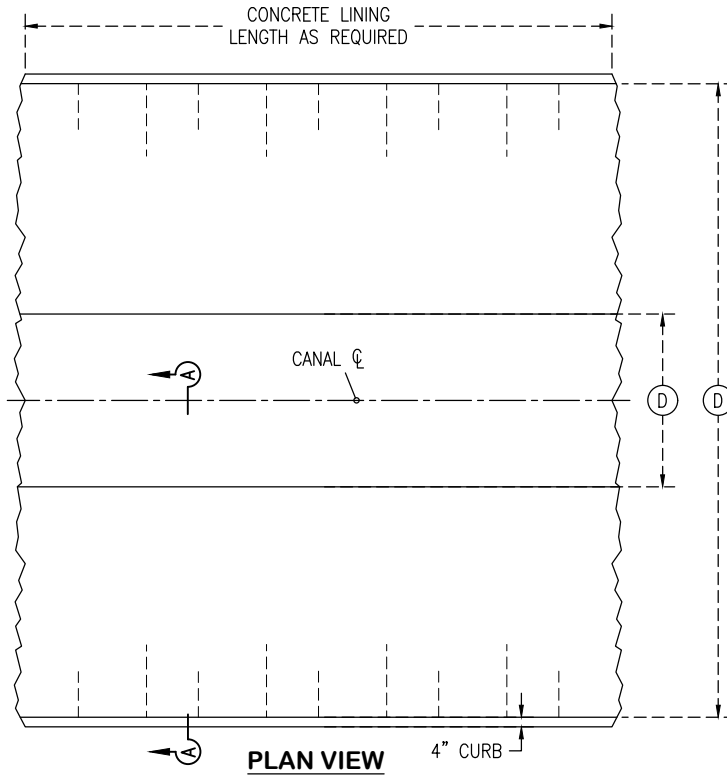

SECTION A-A
SYMMETRICAL ABOUT Q OF CANAL

EXPLANATION OF SYMBOLS

- (E) EXISTING
- (D) DIMENSIONS (TOP WIDTH, BOTTOM WIDTH, DEPTH, ETC.) AS SPECIFIED BY ENGINEER'S DESIGN

PRELIMINARY
 For Review Only
 Subject to Revision
 MAY 22, 2026

PATTERSON IRRIGATION DISTRICT PATTERSON CALIFORNIA	
STANDARD DETAILS STANDARD CANAL LINING	
SUMMERS ENGINEERING INC. HANFORD Consulting Engineers CALIFORNIA	
DATE --- DRAWN ARA CHECKED JCL DATE _____	APPROVED _____ DRAWING NO. SD-L-1 SHEET 23 OF 26 DRAWING NAME : PID 20011.DWG

PATTERSON IRRIGATION DISTRICT
 APPROVED _____
 DATE _____

GENERAL NOTES

- 1. WALL OPENING REINFORCEMENT BARS SHALL BE ONE BAR SIZE LARGER THAN DESIGN WALL REINFORCEMENT BARS, AND WELDED TO INTERSECTING WALL REINFORCEMENT.
- 2. ALL REINFORCING BARS SHALL BE GRADE 60, CONFORMING TO ASTM A-706. ALL REINFORCING BAR BENDS SHALL HAVE A MINIMUM RADIUS OF FOUR BAR DIAMETERS AND SPLICES SHALL BE LAPPED FORTY BAR DIAMETERS.
- 3. WATERSTOP SHALL BE SIKA HYDROTITE HYDROPHILIC PLACED AROUND OUTSIDE OF ALL PENETRATING PIPES.

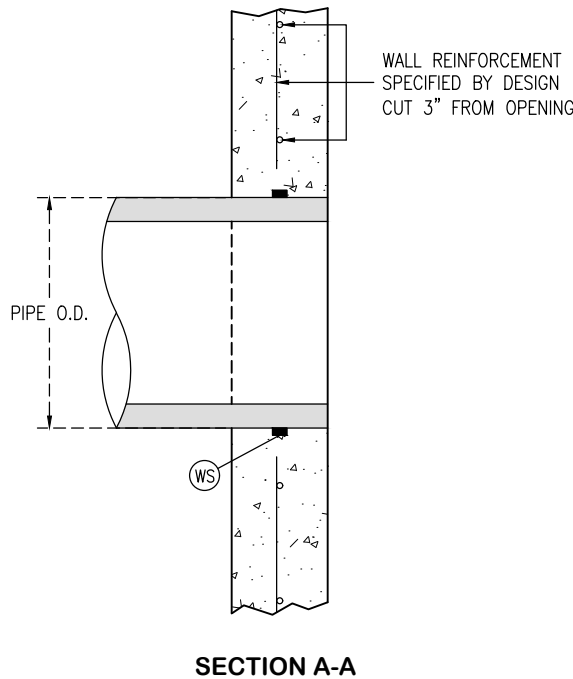
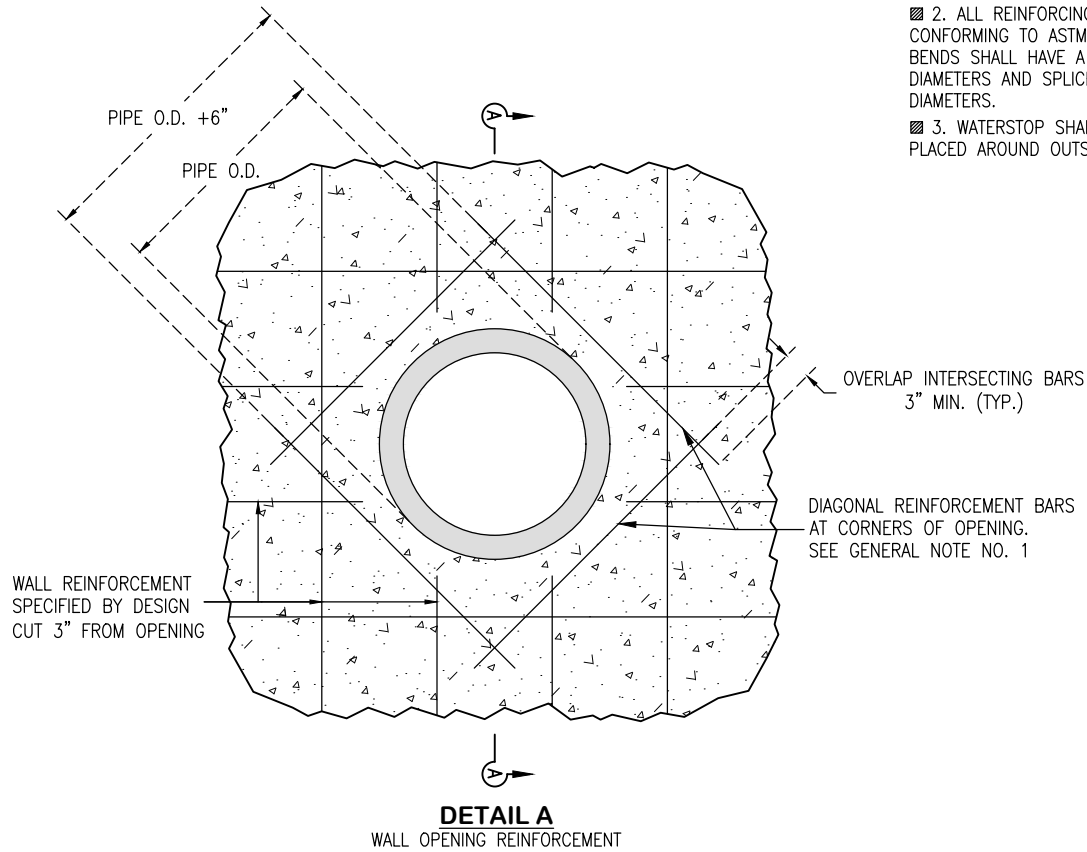

EXPLANATION OF SYMBOLS

- (E) EXISTING
- (WS) WATER STOP, SEE GENERAL NOTE NO. 3

PATTERSON IRRIGATION DISTRICT PATTERSON CALIFORNIA	
STANDARD DETAILS	
CONCRETE WALL OPENING REINFORCEMENT	
SUMMERS ENGINEERING INC. HANFORD CONSULTING ENGINEERS CALIFORNIA	
DATE: ---	APPROVED: _____
DRAWN: ARA	DRAWING NO. SD-R-1
CHECKED: JCL	SHEET 24 OF 26
DRAWING NAME: PID 20011.DWG	

PRELIMINARY
 For Review Only
 Subject to Revision
 MAY 22, 2026

PATTERSON IRRIGATION DISTRICT

APPROVED: _____

DATE: _____

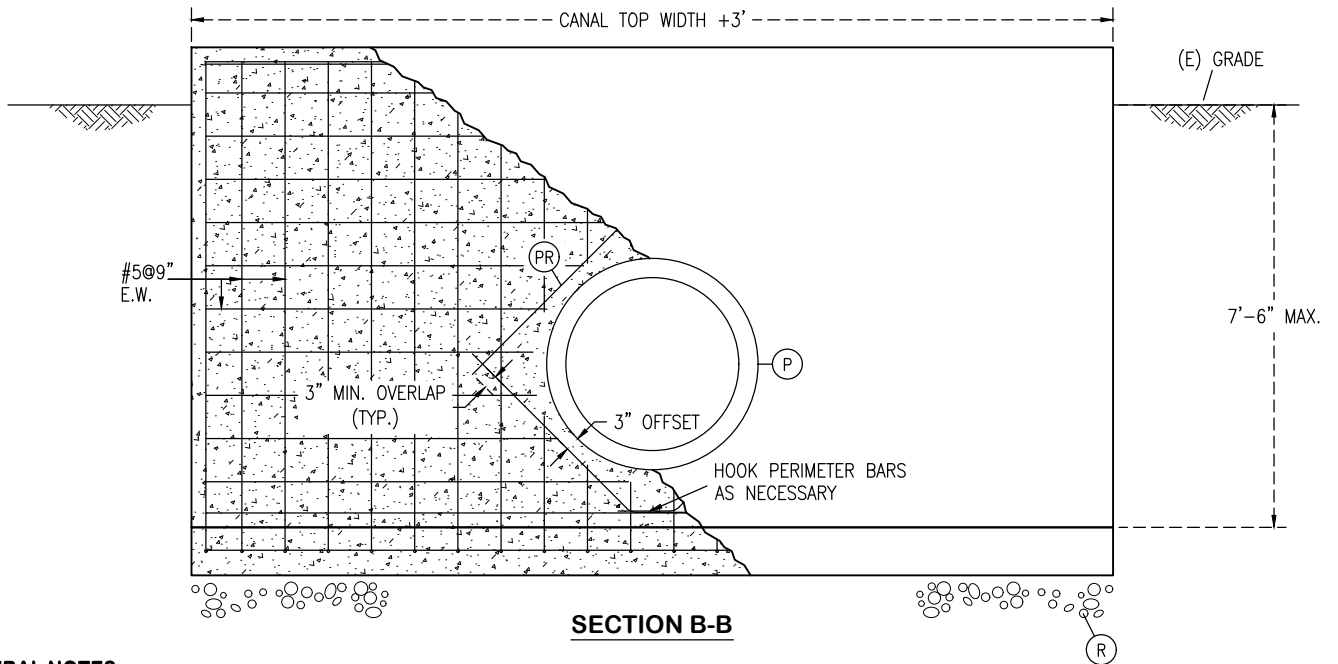
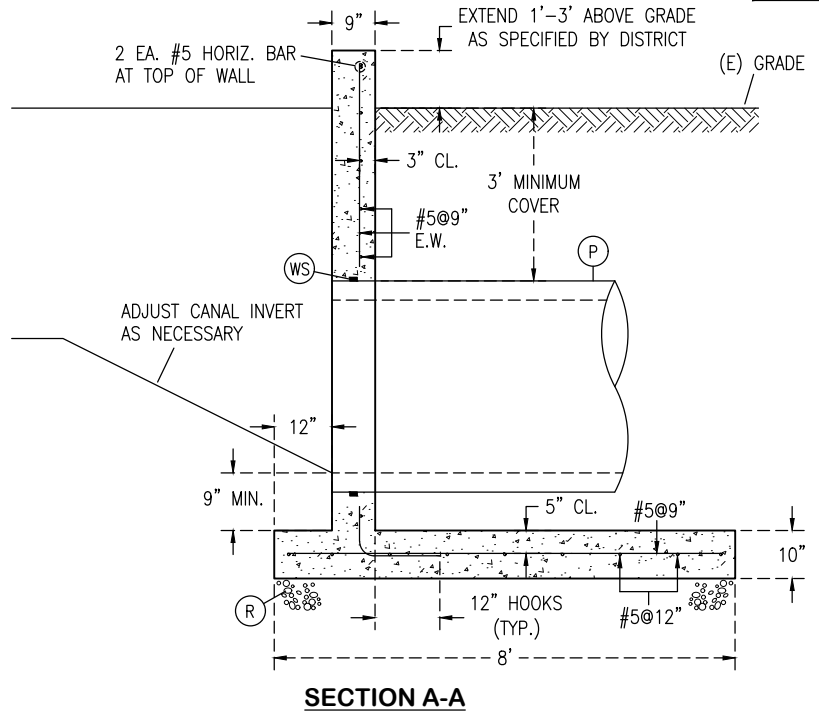
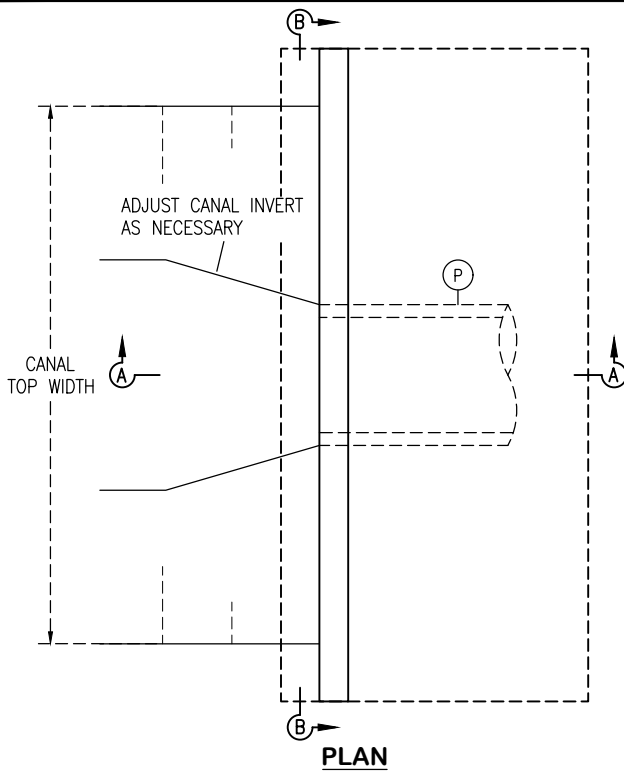

GENERAL NOTES

- 1. REINFORCED CONCRETE SHALL DEVELOP A MINIMUM COMPRESSIVE STRENGTH OF 4000 PSI. CEMENT SHALL BE TYPE II IN ACCORDANCE WITH ASTM C-150. A MINIMUM OF 6 SACKS OF CEMENT TO EACH CUBIC YARD OF CONCRETE SHALL BE USED.
- 2. ALL REINFORCING BARS SHALL BE GRADE 60, CONFORMING TO ASTM A-706. ALL REINFORCING BAR BENDS SHALL HAVE A MINIMUM RADIUS OF FOUR BAR DIAMETERS AND SPLICES SHALL BE LAPPED FORTY BAR DIAMETERS.
- 3. WATERSTOP SHALL BE SIKA HYDROTITE HYDROPHILIC PLACED AROUND OUTSIDE OF ALL PENETRATING PIPES.
- 4. SUBGRADE TO BE COMPACTED TO 90% MAX DRY DENSITY PER ASTM D-1557 PRIOR TO PLACEMENT OF ROCK.
- 5. WALL OPENINGS SHALL BE REINFORCED WITH DIAGONAL #6 BARS AT EACH CORNER OF THE OPENING AND WELDED TO WALL REINFORCEMENT. BARS TO BE OFFSET FROM OPENING BY 3" AND OVERLAP 3" MIN. AT INTERSECTING POINTS.
- 6. THIS STANDARD DETAIL ONLY APPLIES TO PIPE DIAMETERS OF 36" OR SMALLER. FURTHER ENGINEERING SERVICES REQUIRED FOR LARGER DIAMETERS.

EXPLANATION OF SYMBOLS

- (E) EXISTING
- (P) CULVERT PIPE
- (PR) WALL OPENING PERIMETER REINFORCEMENT. SEE GENERAL NOTE NO. 5
- (R) 12" THICK LAYER OF 1 1/2" ROCK
- (WS) WATER STOP, SEE GENERAL NOTE NO. 3

PRELIMINARY
For Review Only
Subject to Revision
MAY 22, 2026

PATTERSON IRRIGATION DISTRICT
APPROVED _____
DATE _____

PATTERSON IRRIGATION DISTRICT
PATTERSON CALIFORNIA

STANDARD DETAILS

ROAD CROSSING HEADWALL FOR 4'-6" DEEP LATERAL

SUMMERS ENGINEERING INC.
HANFORD CONSULTING ENGINEERS CALIFORNIA

DATE	APPROVED
DRAWN ARA	DRAWING NO. SD-HW-1
CHECKED JCL	SHEET 25 OF 26
DRAWING NAME: PID 20011.DWG	

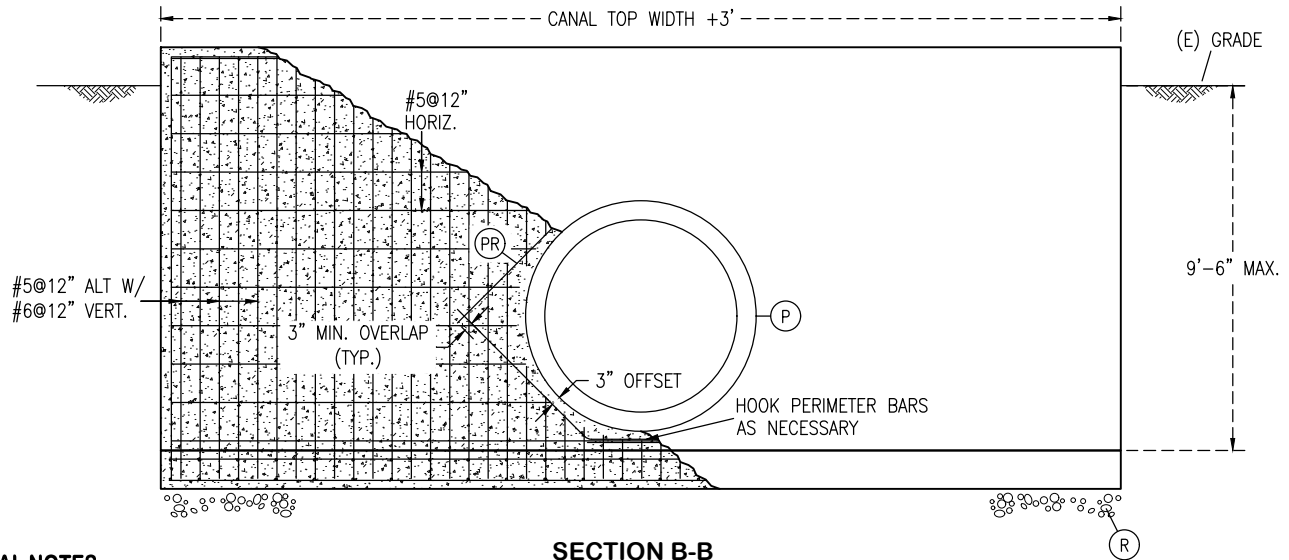
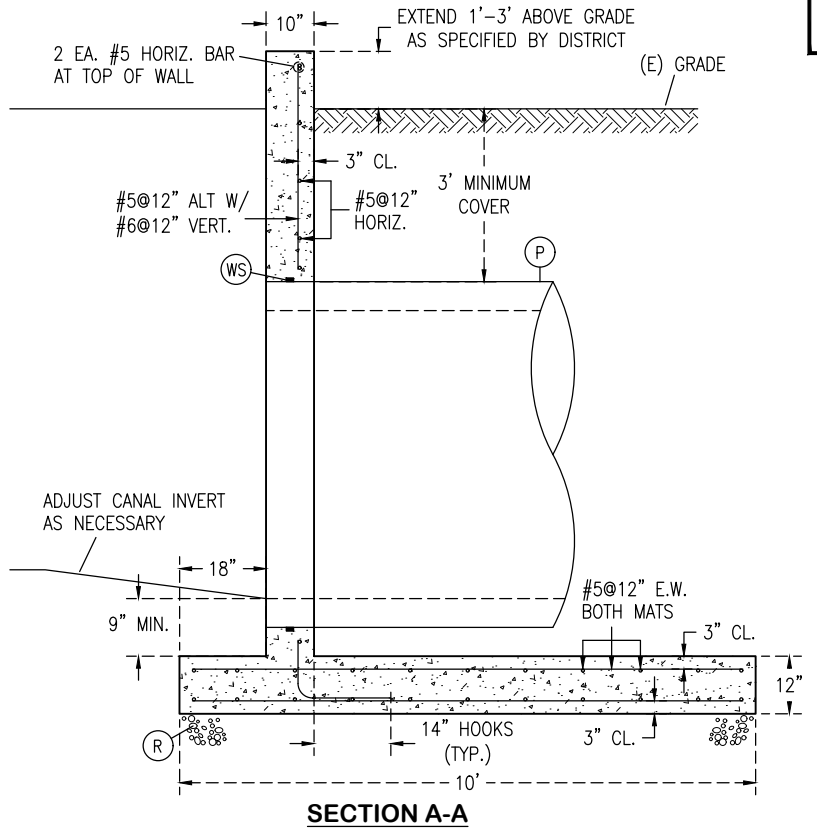
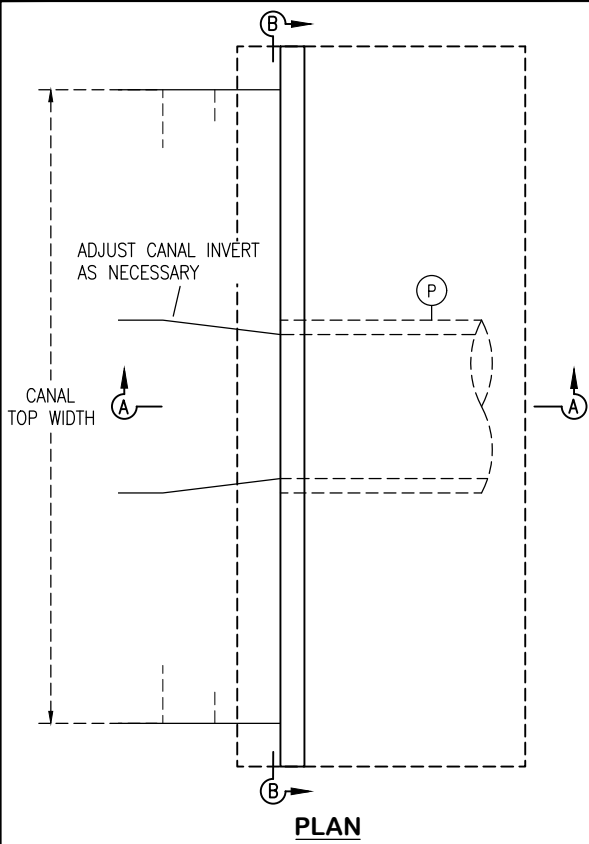

GENERAL NOTES

- 1. REINFORCED CONCRETE SHALL DEVELOP A MINIMUM COMPRESSIVE STRENGTH OF 4000 PSI. CEMENT SHALL BE TYPE II IN ACCORDANCE WITH ASTM C-150. A MINIMUM OF 6 SACKS OF CEMENT TO EACH CUBIC YARD OF CONCRETE SHALL BE USED.
- 2. ALL REINFORCING BARS SHALL BE GRADE 60, CONFORMING TO ASTM A-706. ALL REINFORCING BAR BENDS SHALL HAVE A MINIMUM RADIUS OF FOUR BAR DIAMETERS AND SPLICES SHALL BE LAPPED FORTY BAR DIAMETERS.
- 3. WATERSTOP SHALL BE SIKA HYDROTITE HYDROPHILIC PLACED AROUND OUTSIDE OF ALL PENETRATING PIPES.
- 4. SUBGRADE TO BE COMPACTED TO 90% MAX DRY DENSITY PER ASTM D-1557 PRIOR TO PLACEMENT OF ROCK.
- 5. WALL OPENINGS SHALL BE REINFORCED WITH DIAGONAL #7 BARS AT EACH CORNER OF THE OPENING AND WELDED TO WALL REINFORCEMENT. BARS TO BE OFFSET FROM OPENING BY 3" AND OVERLAP 3" MIN. AT INTERSECTING POINTS.
- 6. THIS STANDARD DETAIL ONLY APPLIES TO PIPE DIAMETERS OF 60" OR SMALLER. FURTHER ENGINEERING SERVICES REQUIRED FOR LARGER DIAMETERS.

EXPLANATION OF SYMBOLS

- (E) EXISTING
- (P) ROAD CROSSING CULVERT PIPE
- (PR) WALL OPENING PERIMETER REINFORCEMENT. SEE GENERAL NOTE NO. 5
- (R) 12" THICK LAYER OF 1 1/2" ROCK
- (WS) WATER STOP, SEE GENERAL NOTE NO. 3

PRELIMINARY
For Review Only
Subject to Revision
MAY 22, 2026

PATTERSON IRRIGATION DISTRICT PATTERSON CALIFORNIA	
STANDARD DETAILS	
ROAD CROSSING HEADWALL FOR 8' DEEP LATERAL	
SUMMERS ENGINEERING INC. HANFORD CONSULTING ENGINEERS CALIFORNIA	
DATE: ---	APPROVED: _____
DRAWN: ARA	DRAWING NO. SD-HW-2
CHECKED: JCL	SHEET 26 OF 26
DRAWING NAME: PID 20011.DWG	

PATTERSON IRRIGATION DISTRICT

APPROVED: _____

DATE: _____